

brother[®]

**LASER PRINTER
SERVICE MANUAL**

MODEL:HL-1060

© Copyright Brother 1997

All rights reserved.

No part of this publication may be reproduced in any form or by any means without permission in writing from the publisher.

Specifications are subject to change without notice.

Trademarks:

The brother logo is a registered trademark of Brother Industries, Ltd.

Apple, the Apple Logo, and Macintosh are trademarks, registered in the United States and other countries, and True Type is a trademark of Apple Computer, Inc.

Epson is a registered trademark and FX-80 and FX-850 are trademarks of Seiko Epson Corporation. Hewlett Packard is a registered trademark and HP Laser Jet is a trademark of Hewlett Packard Company.

IBM, IBM PC and Proprinter are registered trademarks of International Business Machines Corporation.

Microsoft and MS-DOS are registered trademarks of Microsoft Corporation.

Windows is a registered trademark of Microsoft Corporation in the U.S. and other countries.

PREFACE

This service manual contains basic information required for after-sales service of the laser printer (here- in-after referred to as "this machine" or "the printer"). This information is vital to the service technician to maintain the high printing quality and performance of the printer.

This service manual covers the HL-1060 laser printer.

This manual consists of the following chapters:

CHAPTER I : FEATURES AND SPECIFICATIONS

Features, specifications, etc.

CHAPTER II : THEORY OF OPERATION

Basic operation of the mechanical system, the electrical system and the electrical circuits, and their timing information.

CHAPTER III : DISASSEMBLY AND REASSEMBLY

Procedures for disassembling and reassembling the mechanical system.

CHAPTER IV : MAINTENANCE AND TROUBLESHOOTING

Reference values and adjustments, troubleshooting image defects, troubleshooting malfunctions, etc.

APPENDICES :SERIAL NO. DESCRIPTIONS, CONNECTION DIAGRAMS, PCB CIRCUIT DIAGRAMS.

Information in this manual is subject to change due to improvement or re-design of the product. All relevant information in such cases will be supplied in service information bulletins (Technical Information).

A thorough understanding of this printer, based on information in this service manual and service information bulletins, is required for maintaining its print quality performance and for improving the practical ability to find the cause of problems.

CONTENTS

CHAPTER I	FEATURES AND SPECIFICATIONS	I-1
1.	FEATURES	I-1
2.	SPECIFICATIONS	I-3
2.1	Printing	I-3
2.2	Functions	I-3
2.3	Electrical and Mechanical	I-4
2.4	Paper Specification	I-5
2.5	Print Delivery	I-6
2.6	Paper	I-6
2.7	Effective Printing Area	I-7
3.	SAFETY INFORMATION	I-9
3.1	Laser Safety (110 - 120V Model only)	I-9
3.2	FDA Regulations (110 - 120V Model only)	I-9
3.3	Caution for Laser Product	I-10
CHAPTER II	THEORY OF OPERATION	II-1
1.	ELECTRONICS	II-1
1.1	General Block Diagram	II-1
1.2	Main PCB Block Diagram	II-2
1.3	Main PCB	II-3
1.3.1	CPU Core	II-3
1.3.2	ASIC	II-4
1.3.3	ROM	II-7
1.3.4	Optional ROM	II-7
1.3.5	DRAM	II-8
1.3.6	Optional RAM	II-9
1.3.7	Optional Serial I/O	II-10
1.3.8	EEPROM	II-10
1.3.9	Reset Circuit	II-11
1.3.10	Parallel I/O	II-11
1.3.11	Engine I/O	II-12
1.3.12	Paper Feed Motor Drive Circuit	II-13
1.4	Driver PCB	II-13
1.5	SW Panel PCB	II-13
1.6	Power Supply	II-14
1.6.1	Low-voltage Power Supply	II-14
1.6.2	High-voltage Power Supply, SR PCB	II-15
2.	MECHANICS	II-16
2.1	Overview of Printing Mechanism	II-16
2.2	Paper Transfer	II-17
2.2.1	Paper Supply	II-17
2.2.2	Paper Registration	II-17
2.2.3	Paper Eject	II-18

2.3	Sensors.....	II-19
2.3.1	Cover Sensor	II-19
2.3.2	Toner Empty Sensor	II-19
2.4	Drum Unit.....	II-20
2.4.1	Photosensitive Drum	II-20
2.4.2	Primary Charger	II-20
2.4.3	Developer Roller.....	II-20
2.4.4	Transfer Roller.....	II-20
2.4.5	Cleaner Roller.....	II-20
2.4.6	Erase Lamp	II-20
2.5	Print Process	II-20
2.5.1	Charging	II-20
2.5.2	Exposure Stage.....	II-21
2.5.3	Developing.....	II-22
2.5.4	Transfer	II-22
2.5.5	Drum Cleaning Stage	II-23
2.5.6	Erasing Stage.....	II-23
2.5.7	Fixing Stage.....	II-23
CHAPTER III DISASSEMBLY AND REASSEMBLY		III-1
1.	SAFETY PRECAUTIONS.....	III-1
2.	DISASSEMBLY FLOW.....	III-2
3.	DISASSEMBLY PROCEDURE	III-3
3.1	Drum Unit.....	III-3
3.2	Output Tray ASSY	III-3
3.3	Top Cover	III-4
3.4	MP Sheet Feeder 1 ASSY	III-4
3.5	MP Sheet Feeder 2 ASSY	III-7
3.6	Under Shoot ASSY	III-7
3.7	SR PCB / Relay PCB	III-9
3.8	Fixing Unit.....	III-10
3.9	Scanner Unit.....	III-14
3.10	Main PCB ASSY	III-15
3.11	Base Plate ASSY	III-15
3.12	Driver PCB ASSY	III-17
3.13	Low-voltage Power Supply PCB ASSY	III-18
3.14	High-voltage Power Supply PCB ASSY	III-19
3.15	Fan Motor ASSY	III-19
3.16	Drive Unit.....	III-20
3.17	Main Motor ASSY	III-21
3.18	Gears and Solenoid	III-22
3.19	Paper Support.....	III-24
3.20	Extension Support Wire	III-24
4.	PACKING	III-25

CHAPTER IV MAINTENANCE AND TROUBLESHOOTING..... IV-1

1. INTRODUCTION.....	IV-1
1.1 Initial Check	IV-1
1.2 Basic Procedure	IV-2
2. CONSUMABLE PARTS	IV-2
2.1 Drum Unit.....	IV-2
2.2 Toner Cartridge.....	IV-2
2.3 Periodical Replacement Parts	IV-3
3. IMAGE DEFECTS	IV-4
3.1 Image Defect Examples.....	IV-4
3.2 Troubleshooting Image Defects.....	IV-5
3.3 Location of High-voltage Contacts and Grounding Contacts.....	IV-19
3.4 Location of Feed Roller Shaft and Grounding Contacts	IV-20
4. PAPER JAM.....	IV-21
5. TROUBLESHOOTING MALFUNCTIONS	IV-22
6. INSPECTION MODE.....	IV-27
6.1 Incorporated Inspection Modes	IV-27
6.2 Error Codes	IV-29

APPENDICES

1. Serial No. Descriptions	V-1
2. Connection Diagram.....	V-2
3. Main PCB Circuit Diagram, (1/4)	V-3
4. Main PCB Circuit Diagram, (2/4)	V-4
5. Main PCB Circuit Diagram, (3/4)	V-5
6. Main PCB Circuit Diagram, (4/4)	V-6
7. Driver PCB Circuit Diagram.....	V-7
8. Switch Panel/Solenoid, Bin/Relay PCB Circuit Diagram	V-8
9. Low-voltage Power Supply PCB Circuit Diagram (110 - 240V).....	V-9
10. Low-voltage Power Supply PCB Circuit Diagram (220 - 240V).....	V-10
11. High-voltage Power Supply PCB Circuit Diagram.....	V-11
12. SR PCB Circuit Diagram	V-12

CHAPTER I FEATURES AND SPECIFICATIONS

1. FEATURES

This printer has the following features:

1200dpi Resolution and 10ppm Printing Speed

600 dots per inch (dpi) with microfine toner and ten pages per minute (ppm) printing speed (A4 or Letter size paper). The printer also supports 1200 (H) x 600 (V) dots per inch (dpi) resolution for Windows DIB graphics. (It is recommended to add memory when printing in 1200 x 600dpi mode.)

User-Friendly Operation for Windows

The dedicated printer driver and TrueType™-compatible fonts for Microsoft® Windows 3.1 and Windows 95 are available on the floppy disk supplied with your printer. You can easily install them into your Windows system using our installer program. The driver supports our unique compression mode to enhance printing speed in Windows applications and allows you to set various printer settings including toner saving mode, custom paper size, sleep mode, gray scale adjustment, resolution, and so forth. You can easily setup these print options in the graphic dialog boxes through the Printer Setup menu within the Windows Control Panel.

Printer Status Monitor with Bi-directional Parallel Interface

The printer driver can monitor your printer's status using bi-directional parallel communications.

The printer status monitor program can show the current status of your printer. When printing, an animated dialog box appears on your computer screen to show the current printing process. If an error occurs, a dialog box will appear to let you know what to correct. For example: when your printer is out of paper, the dialog box will display "Paper Empty" and instructions for the corrective action to take.

Versatile Paper Handling

The printer has two multi-purpose sheet feeders and a straight paper path mechanism. From the front Feeder 1, you can load A4, letter, legal, B5, A5, A6, and executive sizes of paper, and various types of media including envelopes, postcards, organizer paper, or your custom paper size. From the rear Feeder 2 you can load A4, letter, legal, B5 and executive sizes of paper. The front Feeder 1 also allows manual paper loading, so you can also use labels and transparencies.

Environment-Friendly

Economy Printing Mode:

This feature will cut your printing cost by saving toner. It is useful to obtain draft copies for proof-reading. You can select from two economy modes 25% toner saving and 50% toner saving, through the Windows printer driver supplied with your printer.

Sleep Mode (Power Save Mode):

Sleep mode automatically reduces power consumption when the printer is not in use. The printer consumes less than 13W when in sleep mode.

Low Running Cost:

The toner cartridge is separate from the drum unit. You need to replace only the toner cartridge after around 2,200 pages, which is cost effective and ecologically friendly.

Remote Printer Console Program for DOS

The utility program, Remote Printer Console (RPC), is available on the floppy disk supplied with your printer. When you operate your computer in the DOS (Disk Operating System) environment, this program allows you to easily change the default settings of the printer such as fonts, page setup, emulations and so on.

This program also provides a status monitor program, which is a Terminate-and-Stay Resident (TSR) program. It can monitor the printer status while running in the background and report the current status or errors on your computer screen.

Popular Printer Emulation Support

This printer supports three printer emulation modes, HP LaserJet 5P, Epson FX-850, and IBM Proprinter XL. The printer also supports Auto-emulation switching between HP and Epson or HP and IBM. If you want to select the printer emulation, you can do it using the Remote Printer Console Program.

Enhanced Memory Management

The printer provides its own data compression technology in its printer hardware and the supplied printer driver software, which can automatically compress graphic data and font data efficiently into the printer's memory. You can avoid memory errors and print most full page 600dpi graphic and text data, including large fonts, with the printer's standard memory.

2. SPECIFICATIONS

2.1 Printing

Print method	Electrophotography by semiconductor laser beam scanning
Resolution	600 x 600dpi (for Windows/DOS) 300 x 300dpi (under Apple Macintosh using optional RS-100M) 1200 x 600dpi (Horizontal x Vertical) (for Windows DIB graphics)
Print speed	10 page/minute (when loading Letter-size paper from the multipurpose sheet feeder 1)
Warm-up	Max. 30 seconds at 23°C (73.4°F)
First print	15 seconds (when loading Letter-size paper from the multipurpose sheet feeder 1)
Print media	Toner cartridge Life Expectancy: 2,200 pages/cartridge (when printing A4 or letter - size paper at 5% print coverage)
Developer	Drum unit, separated from toner cartridge Life Expectancy: 20,000 pages/drum unit (4% coverage, continuous printing) at 20 pages per job 8,000 pages at 1 page per job

2.2 Functions

CPU	IDT 79R3041-20J 20mhz
Emulation	Automatic emulation selection among HP LaserJet 5P, EPSON FX-850, and IBM Proprinter XL BR-Script (option)
Printer driver	Windows 95/Windows™ 3.1 driver, supporting Brother Native Compression mode and bi-directional capability Optional Macintosh® QuickDraw driver (Standard in some countries)
Interface	Bi-directional parallel interface (IEEE 1284 compatible) A RS-422A/RS-232C serial interface is optionally available. (The serial interface is a standard in some countries.)
Memory	2.0Mbytes with Data Compression Technology Expandable up to 34Mbytes with the SIMM
Control panel	1 switch and 5 lamps
Diagnostics	Self-diagnostic program

2.3 Electrical and Mechanical

Power source	U.S.A. and Canada: AC 110 to 120V, 60Hz Europe and Australia: AC 220 to 240V, 50Hz/60Hz
Power consumption	Printing: 280W or less Standing by: 60W or less Sleep: 13W or less
Noise	Printing: 49dB A or less Standing by: 38dB A or less
Temperature	Operating: 10 to 32.5°C (59 to 90.5°F) Storage: 0 to 40°C (38 to 104°F)
Humidity	Operating: 20 to 80% (non condensing) Storage: 10 to 85% (non condensing)
Dimensions (W x D x H)	402 (W) x 439 (D) x 274 (H) (when the output tray is closed and the Multi-purpose sheet feeder is removed.)
Weight	Approx. 9.6kg (21.2lb.) including the drum unit and toner cartridge

2.4 Paper Specification

- (1) Multi-purpose sheet feeder loading
< Sheet Feeder 1 (Front)>

Paper size: A4, Letter, Legal, B5, A5, A6, and Executive, and other sizes of media that can be handled by the feed mechanism, can be loaded.

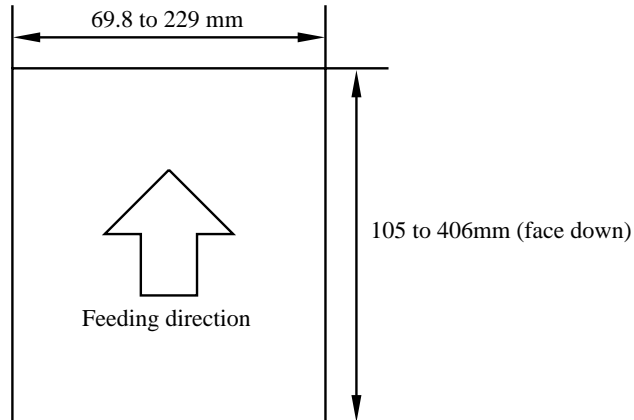

Feedable paper weight: 60 (16lb.) to 157 (42lb.) g/m²

Maximum load height : 22mm (200 sheets of 80g/m² paper) letter size

Envelopes : 10 envelopes

Setting method: Pull the MP sheet feeder 1 cover toward you, insert the stack of paper into the feeder, aligning the top edge of the sheets, then push the cover back to its original position.

<Sheet Feeder 2 (Rear)>

Paper size: A4, Letter, Legal, B5, and Executive, and other sizes of media that can be handled by the feed mechanism, can be loaded, except special papers such as envelopes, OHP sheets, labels and organizer sheets.

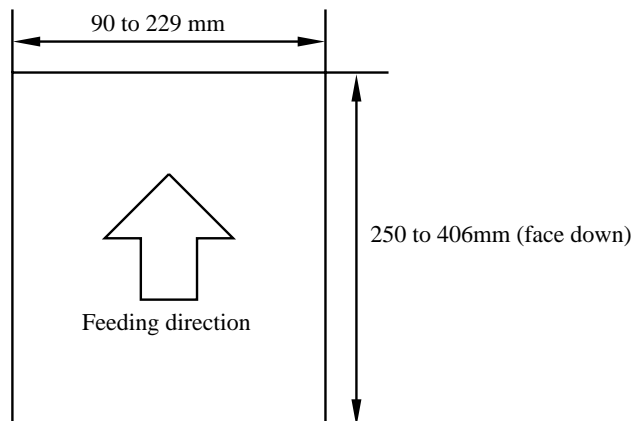

Feedable paper weight: 60 (16lb.) to 157 (42lb.) g/m²

Maximum load height: 22mm (200 sheets of 80g/m² paper) letter size.

Setting method: Pull the MP sheet feeder 2 cover toward you, insert the stack of paper into the feeder, aligning the top edge of the sheets, then push the cover back to its original position.

2.5 Print Delivery

- (1) With the output tray opened
Tray capacity : Maximum 100 sheets (80g/m²), face-down only
- (2) With the output tray closed
Tray capacity : 1 sheet (80g/m²), face-down only

*Note: Face down: Deliver the printed face of the paper downward.
Environment : 23°C*

2.6 Paper

- (1) Types of paper

<Sheet Feeder 1 (Front)>

- (a) Normal paper (60 to 157g/m², specified types of high-quality paper)
 - A4 size
 - Letter size
 - Legal size
 - B5 size
 - A5 size
 - A6 size
 - Executive size
 - 9" envelop size (maximum printable area)

* The recommended types of plain paper are as follows:
Letter : Xerox 4200 (75g/m²)
A4 : Xerox 80 Premier Paper (80g/m²)
- (b) Special paper (specified types)
 - Labels
 - Envelopes (DL, C5, COM10)
 - Postcards
 - Organizers (K, L, and J sizes of DAY-TIMERS)

<Sheet Feeder 2 (Rear)>

- (a) Normal paper (60 to 157g/m², specified types of high-quality paper)
 - A4 size
 - Letter size
 - Legal size
 - B5 size
 - Executive size
 - The specified types of plain paper are as follows:
Letter : Xerox 4200 (75g/m²)
A4 : Xerox 80 Premier Paper

(2) Paper feed conditions

Type	Name	Feeder		Manual feed
		Feeder 1	Feeder 2	
Normal paper (cut sheet)	60 to 80 g/m ²	○ (200 sheets)	○ (200 sheets)	○
	80 g/m ² paper (Legal)	○ (100 sheets)	○ (100 sheets)	○
	157 g/m ²	○ (30 sheets)	○ (30 sheets)	○
Special paper (cut sheet)	Labels	○ (50 sheets)	✕	○
	Envelopes	○ (10 sheets)	✕	○
	Postcards	○ (30 sheets)	✕	○
	Organizers	○ (10 sheets)	✕	○

2.7 Effective Printing Area

Printable area

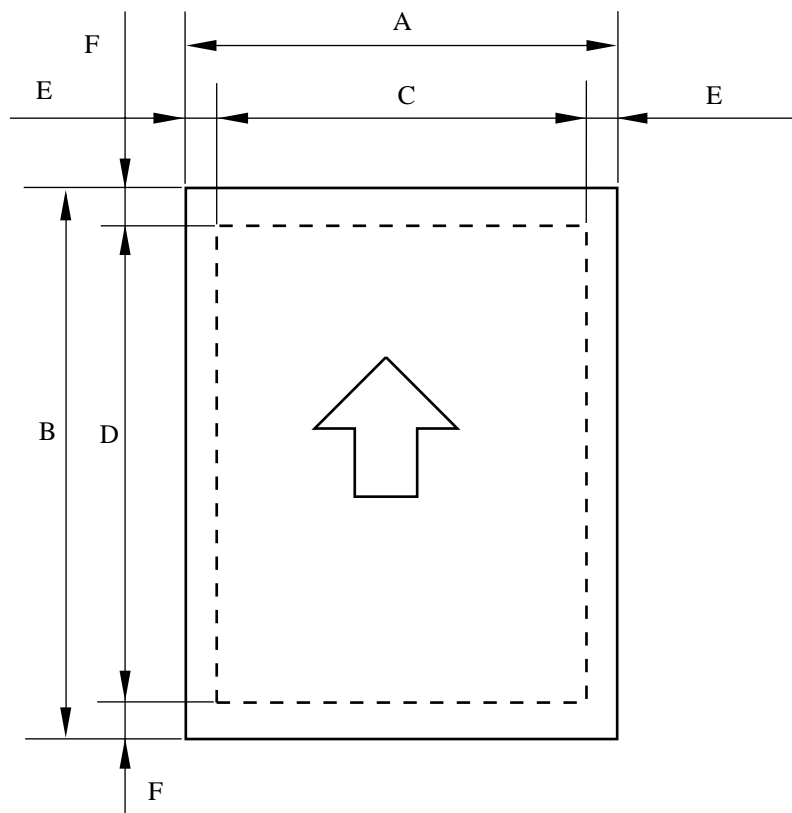

The effective printing area means the area within which the printing of all the data received without any omissions can be guaranteed.

The table below shows the effective printing areas.

Size	A	B	C	D	E	F
A 4	210.0mm 8.27" (2,480 dots)	297.0mm 11.69" (3,507 dots)	203.2mm 8.0" (2,400 dots)	288.5mm 11.36" (3,407 dots)	3.4mm 0.13" (40 dots)	4.23mm 0.17" (50 dots)
Letter	215.9mm 8.5" (2,550 dots)	279.4mm 11.0" (3,300 dots)	203.2mm 8.0" (2,400 dots)	271.0mm 10.67" (3,200 dots)	6.35mm 0.25" (75 dots)	↑
Legal	215.9mm 8.5" (2,550 dots)	355.6mm 14.0" (4,200 dots)	203.2mm 8.0" (2,400 dots)	347.1mm 13.67" (4,100 dots)	↑	↑
B 5 (JIS)	182.0mm 7.16" (2,149 dots)	257.0mm 10.12" (3,035 dots)	170.0mm 6.69" (2,007 dots)	248.5mm 9.78" (2,935 dots)	6.01mm 0.24" (71 dots)	↑
B 5 (ISO)	176.0mm 6.93" (2,078 dots)	250.0mm 9.84" (2,952 dots)	164.0mm 6.46" (1,936 dots)	241.5mm 9.5" (2,852 dots)	↑	↑
Executive	184.15mm 7.25" (2,175 dots)	266.7mm 10.5" (3,150 dots)	175.7mm 6.92" (2,075 dots)	258.3mm 10.17" (3,050 dots)	6.35mm 0.25" (75 dots)	↑
A 5	148.5mm 5.85" (1,754 dots)	210.0mm 8.27" (2,480 dots)	135.8mm 5.35" (1,604 dots)	201.5mm 7.93" (2,380 dots)	6.01mm 0.24" (71 dots)	↑
A6	105.0mm 4.13" (1,240 dots)	148.5mm 5.85" (1,754 dots)	93.0mm 3.66" (1,098 dots)	140.0mm 5.51" (1,654 dots)	↑	↑
Organizer (J size)	69.85mm 2.75" (825 dots)	127.0mm 5.0" (1,500 dots)	57.15mm 2.25" (675 dots)	118.5mm 4.66" (1,400 dots)	6.35mm 0.25" (75 dots)	↑
Organizer (K size)	95.25mm 3.75" (1,125 dots)	171.45mm 6.75" (2,025 dots)	82.55mm 3.25" (975 dots)	162.98mm 6.42" (1,925 dots)	↑	↑
Organizer (L size)	139.7mm 5.5" (1,650 dots)	215.9mm 8.5" (2,550 dots)	127.0mm 5.0" (1,500 dots)	207.43mm 8.17" (2,450 dots)	↑	↑
COM-10	104.78mm 4.125" (1,237 dots)	241.3mm 9.5" (2,850 dots)	92.11mm 3.63" (1,087 dots)	232.8mm 9.16" (2,750 dots)	↑	↑
MONARCH	98.43mm 3.875" (1,162 dots)	190.5mm 7.5" (2,250 dots)	85.7mm 3.37" (1,012 dots)	182.0mm 7.16" (2,150 dots)	↑	↑
C 5	162mm 6.38" (1,913 dots)	229mm 9.01" (2,704 dots)	150.0mm 5.9" (1,771 dots)	220.5mm 8.68" (2,604 dots)	6.01mm 0.24" (71 dots)	↑
DL	110mm 4.33" (1,299 dots)	220mm 8.66" (2,598 dots)	98.0mm 3.86" (1,157 dots)	211.5mm 8.33" (2,498 dots)	↑	↑

(Note that the paper sizes indicated here should conform to the nominal dimensions specified by JIS.)

A4 paper must accommodate 80 characters printed in pica pitch (203.2 mm).

The dot size is based on 300 dpi resolution.

3. SAFETY INFORMATION

3.1 Laser Safety (110 - 120V Model only)

This printer is certified as a Class 1 laser product under the US Department of Health and Human Services (DHHS) Radiation Performance Standard according to the Radiation Control for Health and Safety Act of 1968. This means that the printer does not produce hazardous laser radiation.

Since radiation emitted inside the printer is completely confined within the protective housings and external covers, the laser beam cannot escape from the machine during any phase of user operation.

3.2 FDA Regulations (110 - 120V Model only)

The US Food and Drug Administration (FDA) has implemented regulations for laser products manufactured on and after August 2, 1976. Compliance is mandatory for products marketed in the United States. One of the following labels on the back of the printer indicates compliance with the FDA regulations and must be attached to laser products marketed in the United States.

The label for Japanese manufactured products

<p>MANUFACTURED: BROTHER INDUSTRIES, LTD.</p> <p>15-1, Naeshiro-cho, Mizuho-ku, Nagoya 467, Japan. This product complies with FDA radiation performance standards, 21 CFR Subchapter J.</p>

The label for US manufactured products

<p>MANUFACTURED: BROTHER INDUSTRIES (USA) INC.</p> <p>2950 Brother Blvd., Bartlet, TN 38133, U.S.A. This product complies with FDA radiation performance standards, 21 CFR Subchapter J.</p>
--

Fig. 1.1

3.3 Caution for Laser Product (Warnhinweis für Laserdrucker)

CAUTION: When the machine during servicing is operated with the cover open, the regulations of VBG 93 and the performance instructions for VBG 93 are valid.

CAUTION: In case of any trouble with the laser unit, please replace the laser unit itself. To prevent direct exposure to the laser beam, do not try to open the enclosure of the laser unit.

ACHTUNG: Im Falle von Störungen der Lasereinheit muß diese ersetzt werden. Das Gehäuse der Lasereinheit darf nicht geöffnet werden, da sonst Laserstrahlen austreten können.

- (1) Location of the laser beam window.

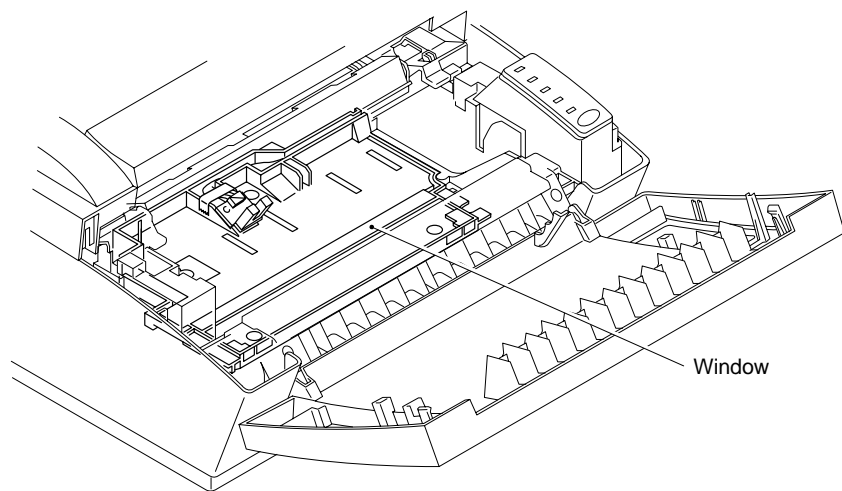

Fig. 1.2

- (2) Location of Caution Label for Laser Product. (200V only)

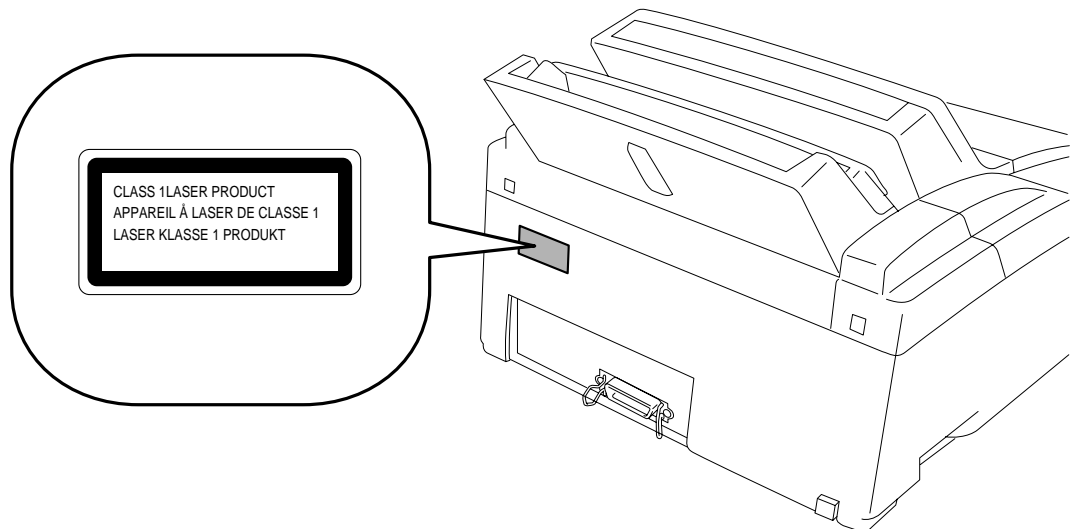

Fig. 1.3

CHAPTER II THEORY OF OPERATION

1. ELECTRONICS

1.1 General Block Diagram

Fig. 2.1 shows a general block diagram of the HL-1060 printer.

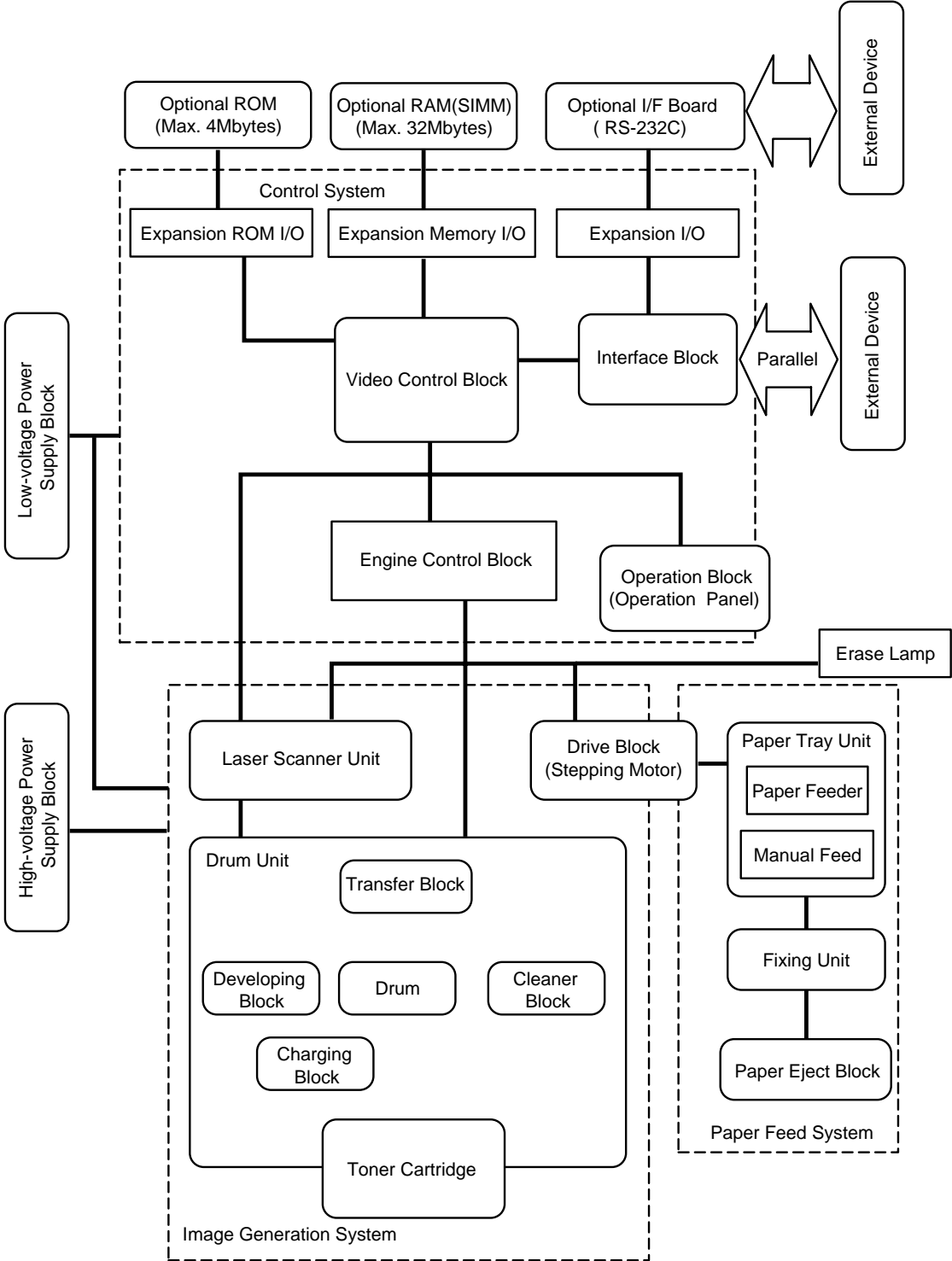

Fig. 2.1

1.3 Main PCB

1.3.1 CPU Core

Fig. 2.3. shows the CPU circuit block on the main PCB.

The CPU is an IDT 79R3041-20J which is driven at a clock frequency of 20MHz. This clock frequency is made by dividing the source clock frequency of 40.0MHz by two. The address and data bus are both 32bits consisting of AD0 to AD31. The total addressable memory space is 4Gbytes.

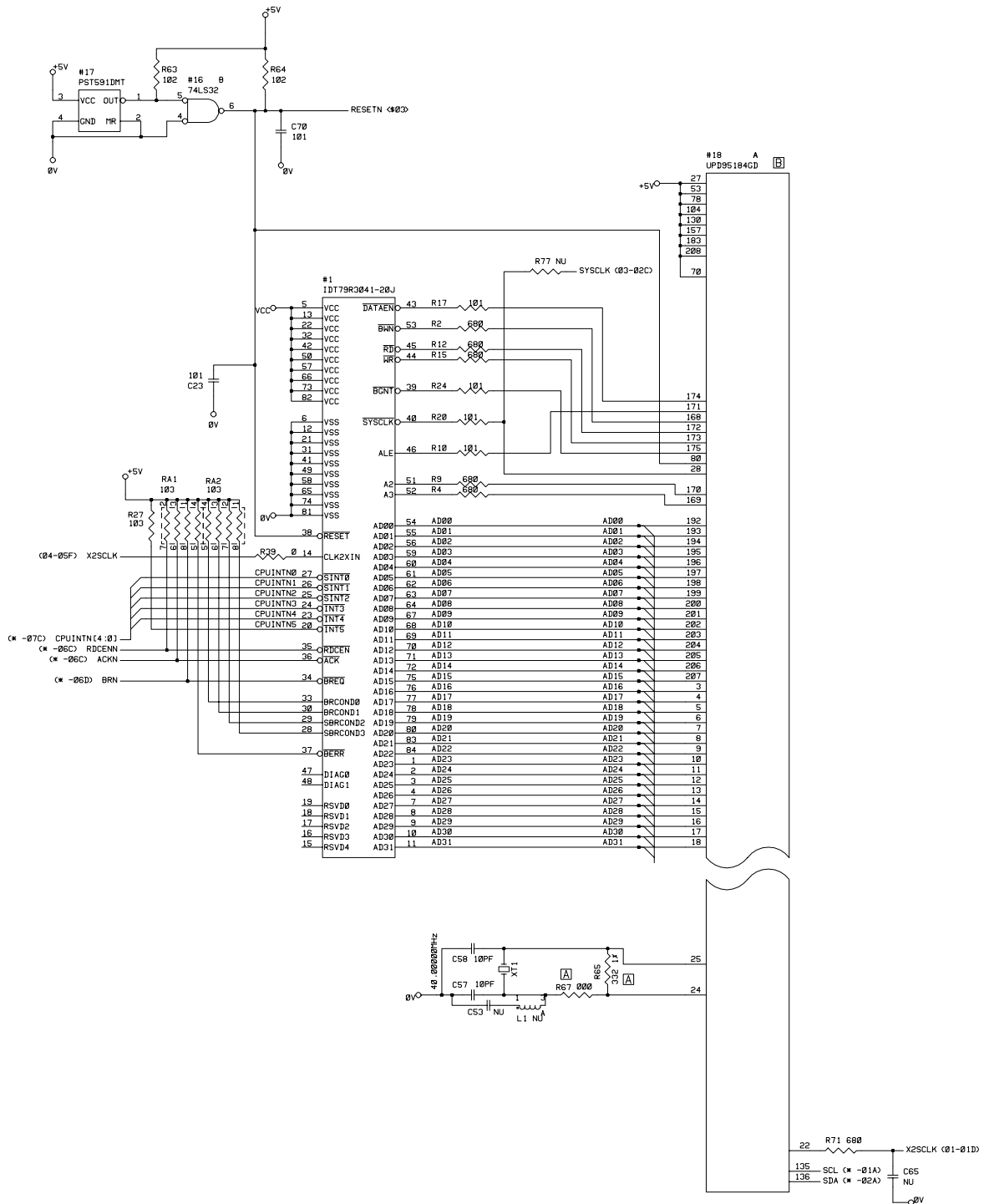

Fig. 2.3

1.3.2 ASIC

The ASIC is composed of a Cell Based IC that contains the following functional blocks.

- (1) Oscillator circuit
Generates the main clock for the CPU by dividing the source clock frequency by two.
- (2) Address Generator
Generates the address bus by latching the AD bus with the ALE signal.
- (3) Address decoder
Generates the CS signal for each device.
- (4) DRAM control
Generates the RAS, CAS, WE, OE and MA signals for the DRAM and controls the refresh processing (CAS before RAS self-refreshing method).
- (5) Interrupt control

Interrupt levels:

Priority	High	9	TIMER 3 (Watch Dog)
		8	MONITOR
		7	FIFO
		6	EXINT
		5	TIMER 1
		4	BD
		3	SPARE
		2	CDCC / BOISE / DATA EXTENTION
	Low	1	TIMER 2

Note: All the interrupts can be masked.

- (6) Timers
The following timers are included:

Timer 1	16-bit timer
Timer 2	10-bit timer
Timer 3	Watch-dog timer
- (7) FIFO
A 10Kbit FIFO is included. Data for one raster is transferred from the RAM to the FIFO by DMA transmission and is output as serial video data. The data cycle is 6.13mhz.

(8) Parallel I/O

<Data receive Mode>

There are two modes in this unit. One is the CPU receive mode and the other is the DMA receive mode. In the CPU receive mode the CPU receives the command data from the PC, and after the CPU is switched to the DMA mode, it receives the image data and writes it to the DRAM directly.

CPU Receive Mode

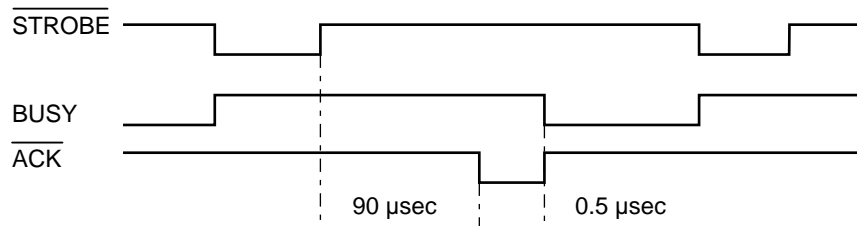

DMA Receive Mode

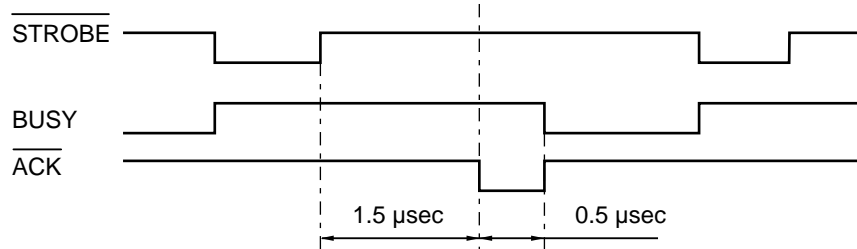

BUSY goes HIGH at the falling edge of the STROBE signal. The data (8 bits) from the PC is latched into the data buffer at the rising edge of the STROBE signal. The pulse width of ACK varies according to the speed MODE as shown above. BUSY goes LOW on the rising edge of ACK.

<IEEE1284 support>

This supports the IEEE1284 data transfer with the following mode.

- Nibble mode
- Byte mode
- ECP mode

(9) Data extension

This circuit extends the compressed image data which are received from the PC, and writes the bit map data to the FIFO.

(10) Software support

Supports 16 x 16 rotation, bit expansion, bit search, and decimal point conversion.

(11) EEPROM I/O

One output port and one I/O port are assigned.

(12) Engine control I/O

This I/O is used for the connection to the driver PCB. It controls the main motor, solenoid, sensors, etc.

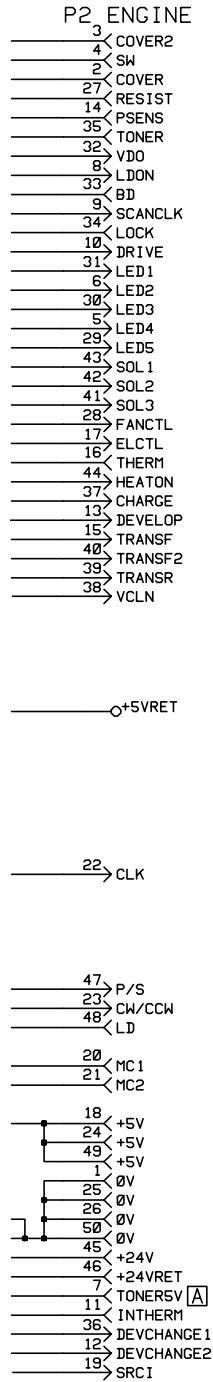

Fig. 2.4

1.3.3 ROM

The program and the font data are stored in 4Mbytes of ROM. The ROM is composed of two 16Mbit masked ROMs which are mounted in 42-pin IC sockets.

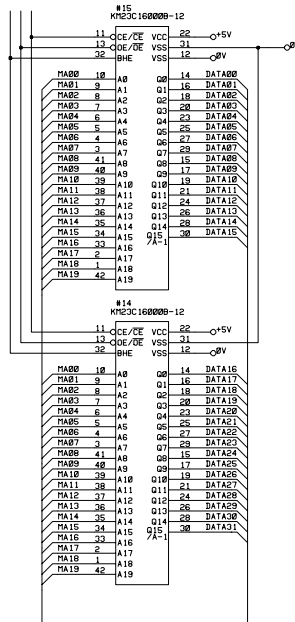

Fig. 2.5

1.3.4 Optional ROM

The program and the font data are stored in 4Mbytes of ROM. The ROM is composed of two 16Mbit masked ROMs which are mounted in 42-pin IC sockets.

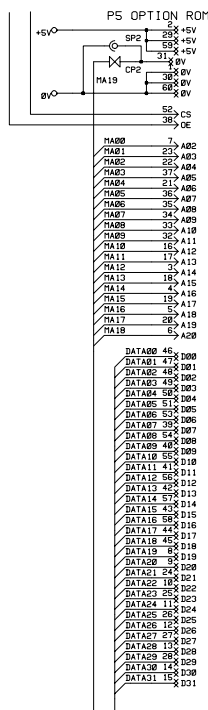

Fig. 2.6

1.3.5 DRAM

Four 4Mbit DRAM (x 8bit) are used as the printer memory.

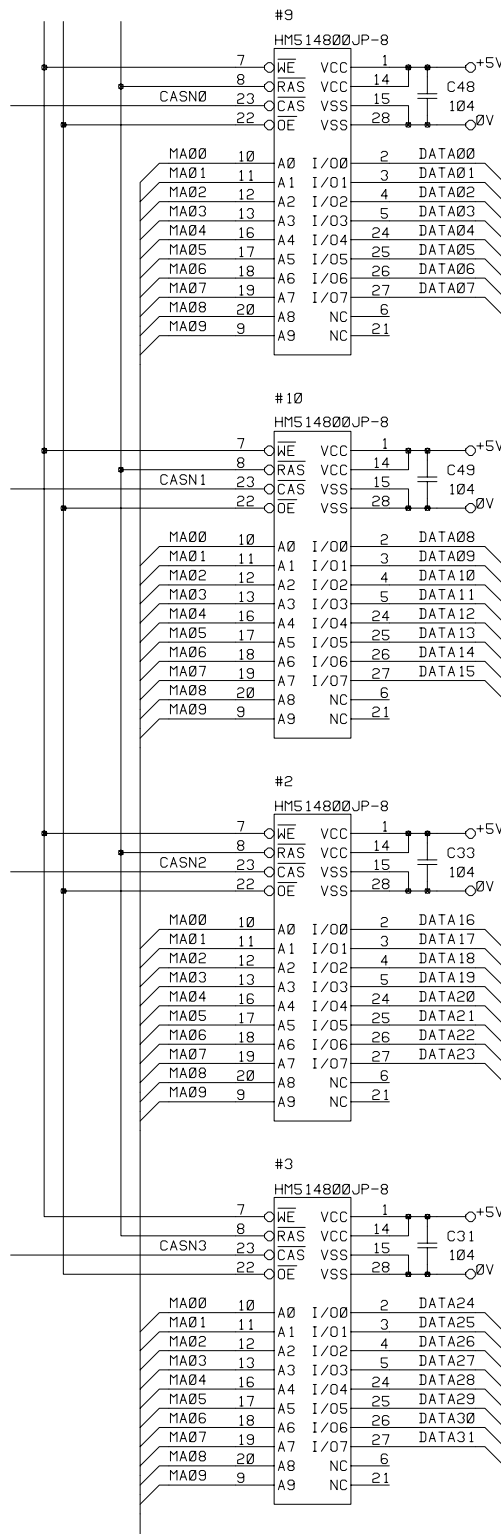

Fig. 2.7

1.3.6 Optional RAM

A 32bit SIMM (72 pin) can be fitted as optional RAM. The main PCB has one slot and its capacity is for SIMM from 1Mbytes to 32Mbytes.

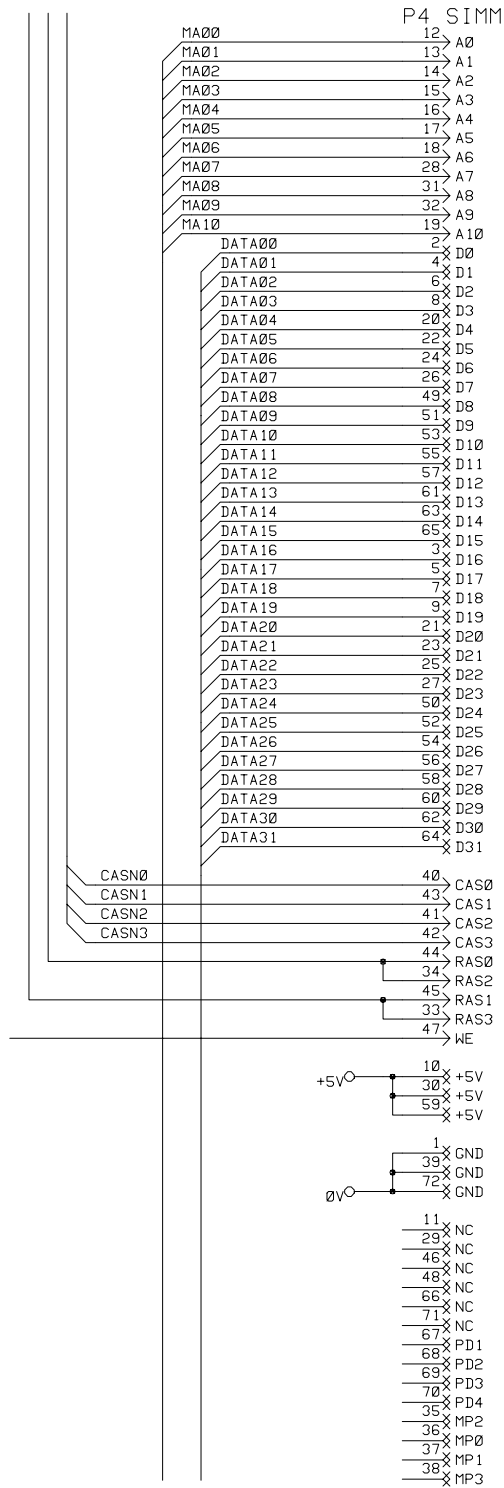

Fig. 2.8

1.3.7 Optional Serial I/O

The interrupt of the serial I/O is input to the EXINT terminal of the ASIC, and recognized by the CPU. A 32-byte space for a register is provided for this I/O, which is read and written to by the CPU.

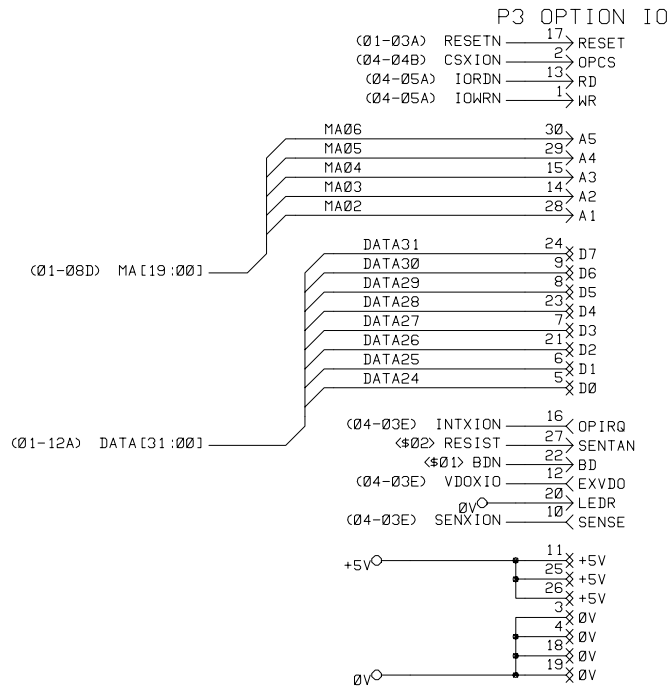

Fig. 2.9

1.3.8 EEPROM

The EEPROM is an X24C04F two-wire type with a 512 x 8bits configuration.

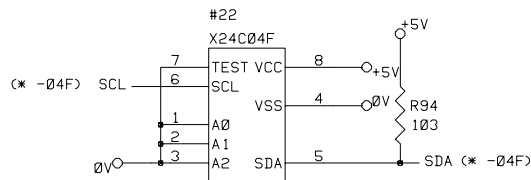

Fig. 2.10

1.3.11 Engine I/O

Fig. 2.13 shows the engine interface circuit.

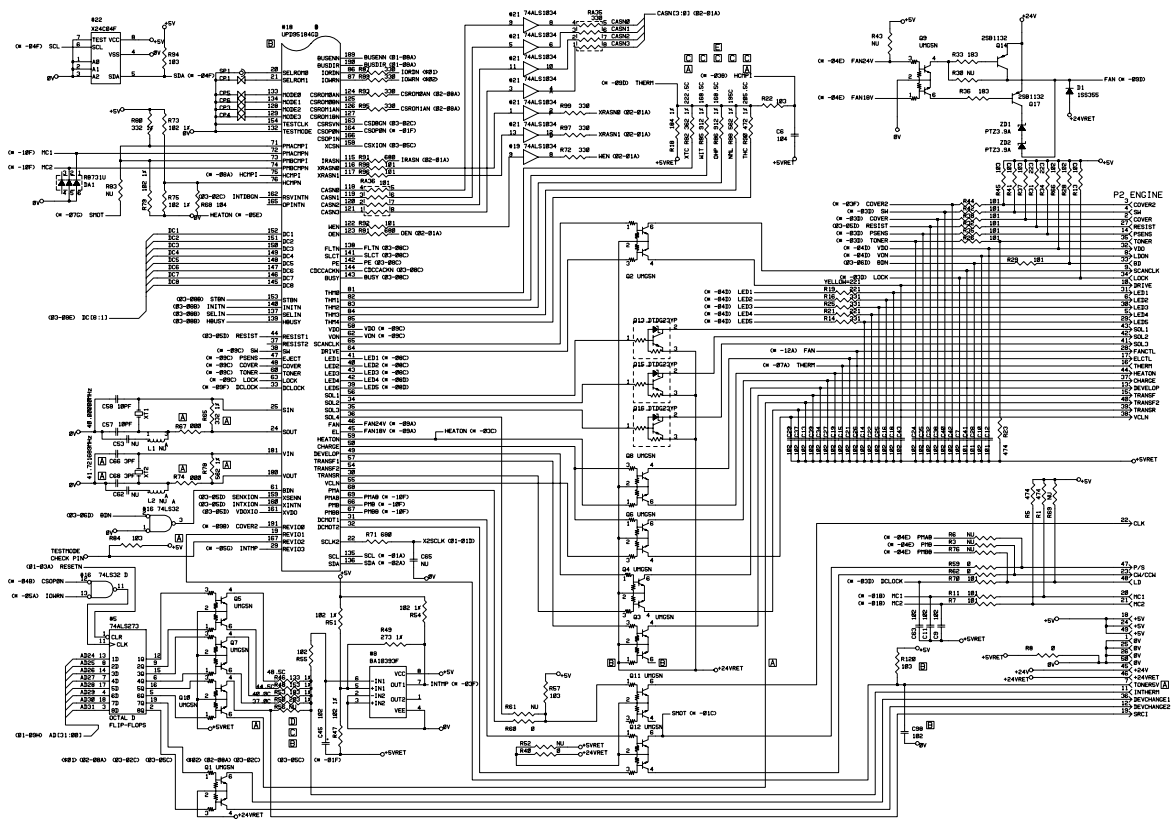

Fig. 2.13

1.3.12 Paper Feed Motor Drive Circuit

A DC motor is used for paper feeding.

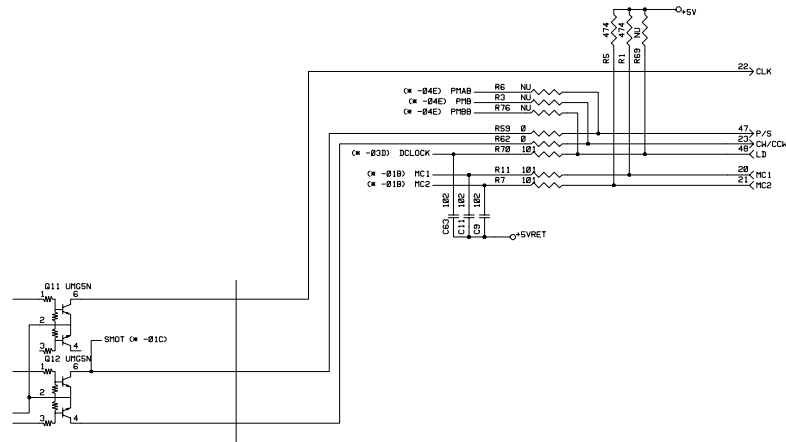

Fig. 2.14

1.4 Driver PCB

The following parts are mounted on the driver PCB.

- ConnectorsLow-voltage, high-voltage, solenoid, main motor, toner sensor, laser, polygon motor, connector for main PCB
- Registration sensor

1.5 SW Panel PCB

The following parts are mounted on the SW panel PCB.

- Operation panel1 Key, 5 LEDs

1.6 Power Supply

1.6.1 Low-voltage Power Supply

The power supply uses a switching regulation system to generate the regulated DC power (+5V and +24V), which are converted from the AC line.

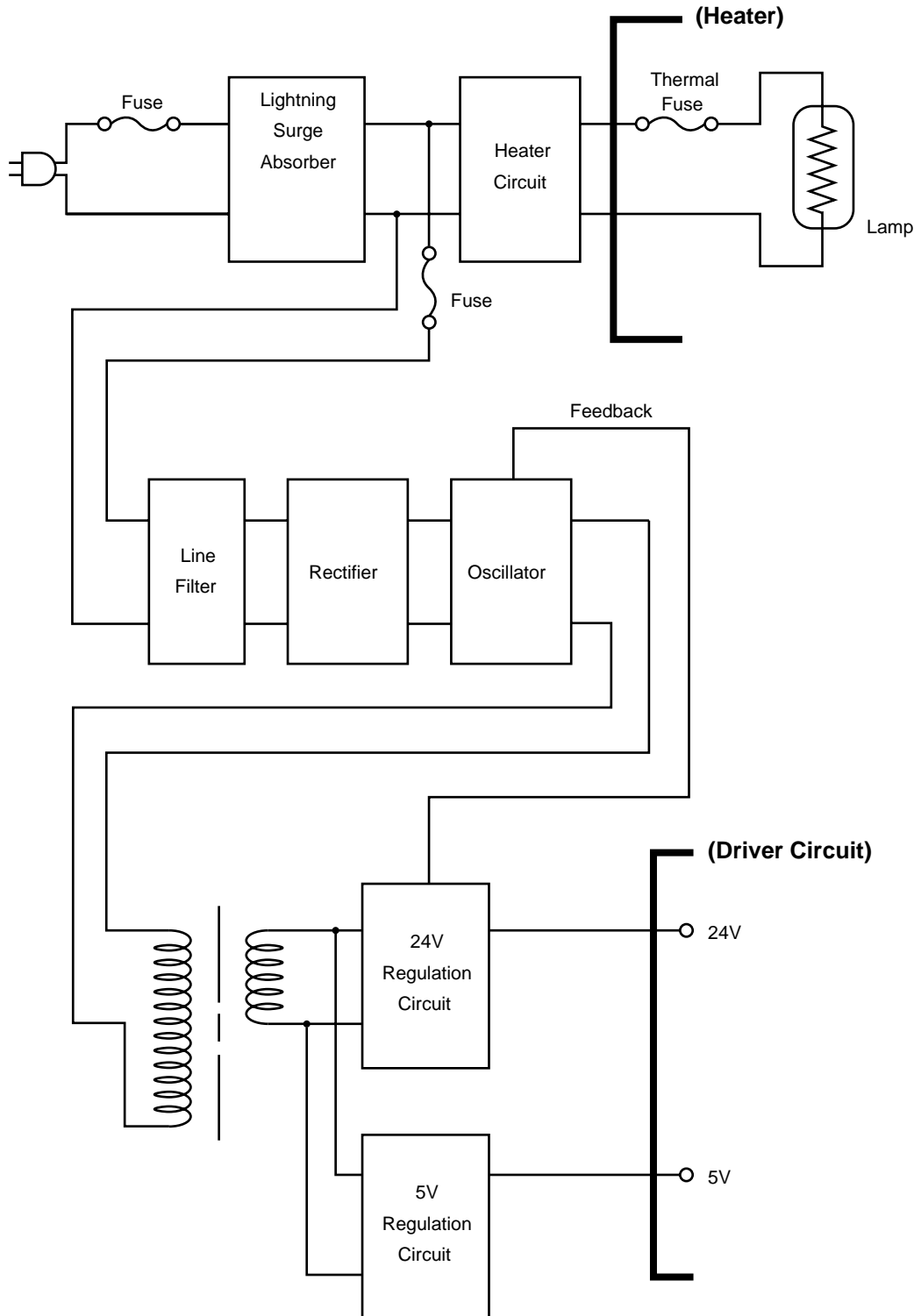

Fig. 2.15

1.6.2 High-voltage Power Supply, SR PCB

This generates and outputs the voltages and currents for the charging, development and transfer functions.

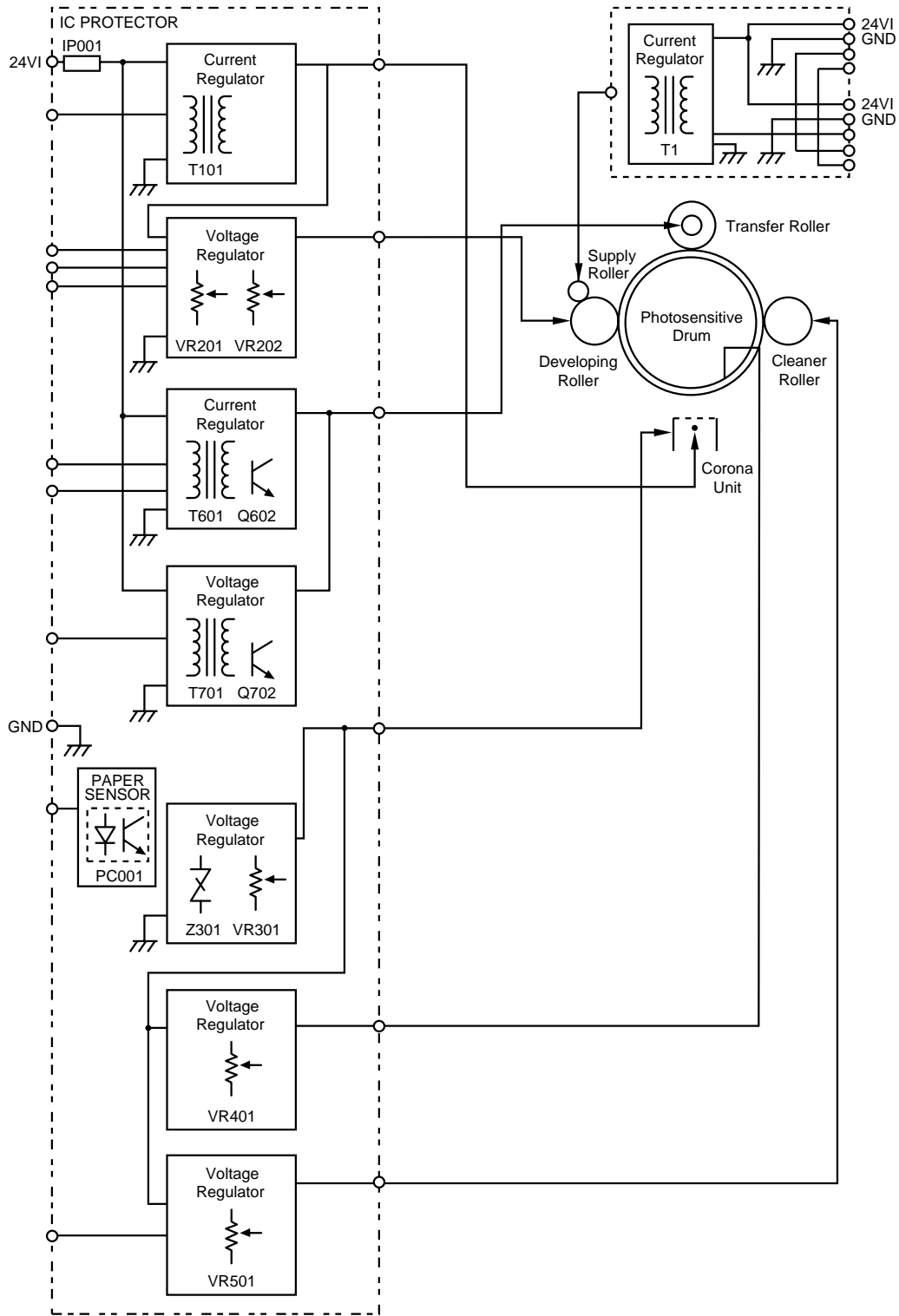

Fig. 2.16

2. MECHANICS

2.1 Overview of Printing Mechanism

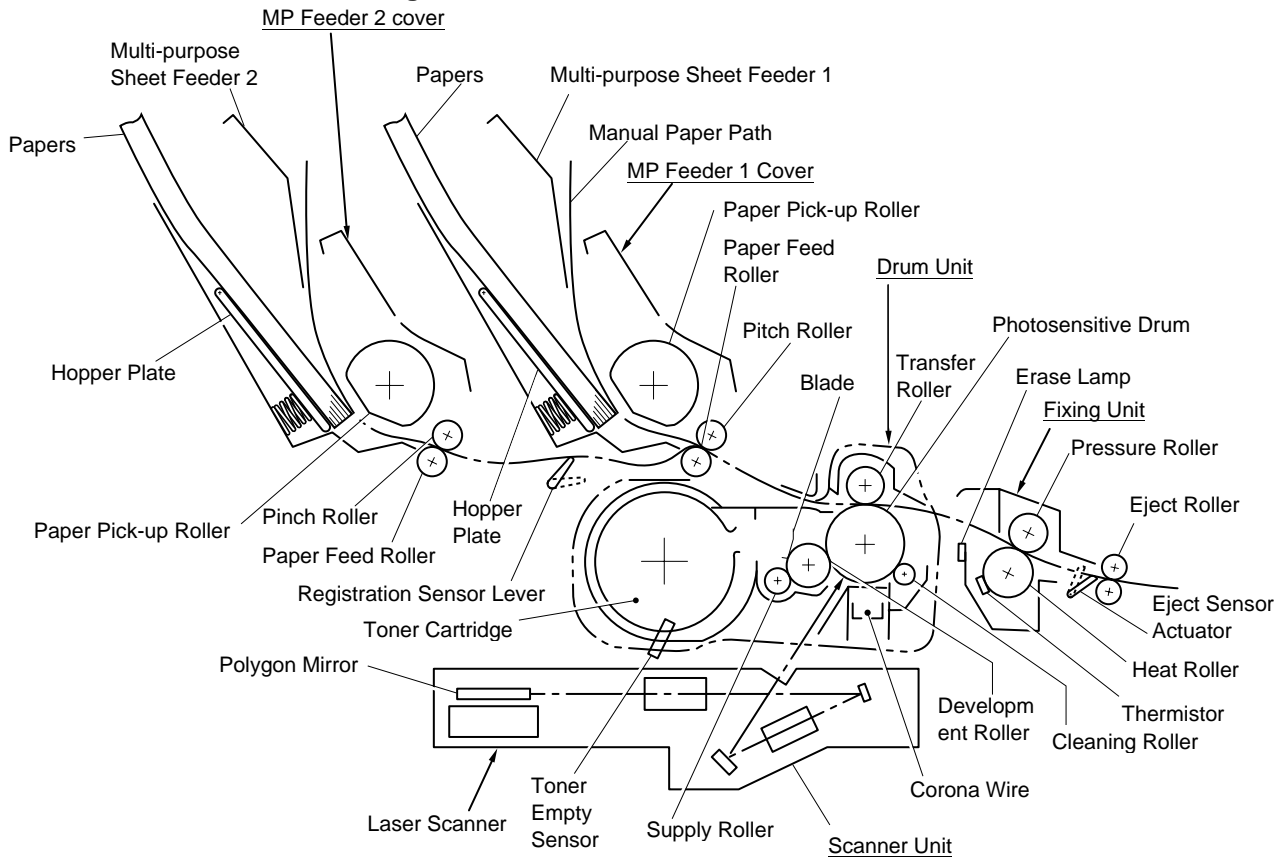

Fig. 2.17

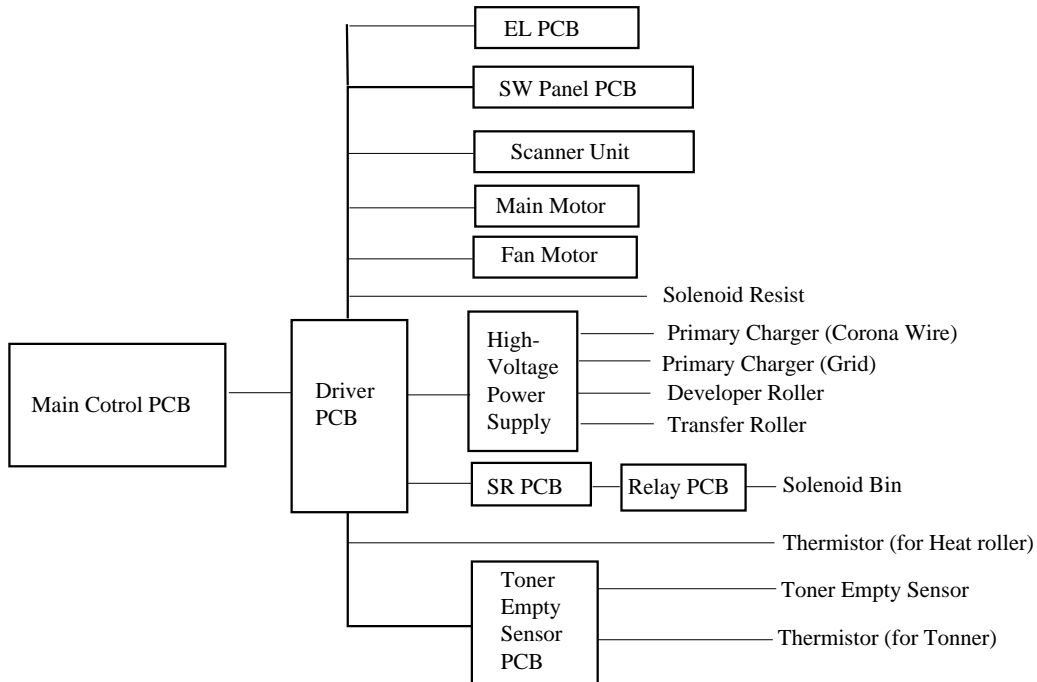

Fig. 2.18

2.2 Paper Transfer

2.2.1 Paper Supply

The pick-up roller picks up one sheet of paper from the paper feeder every time it is rotated and feeds it to the paper feed roller.

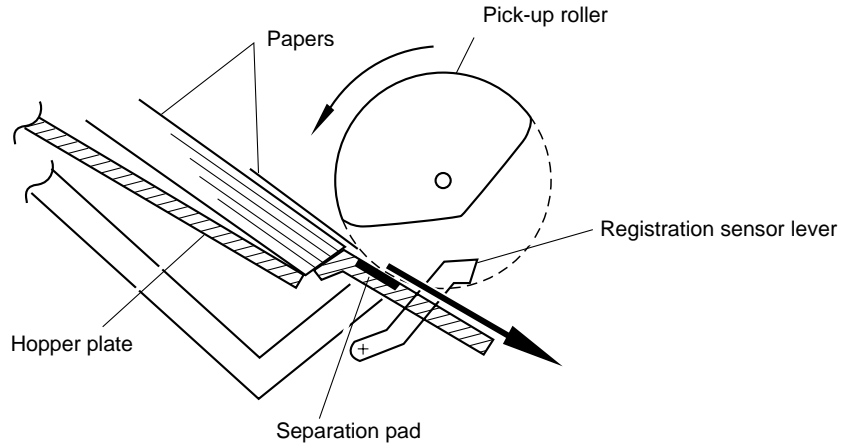

Fig. 2.19

The paper is gripped between the pick-up roller and the separation pad and separated into individual sheets.

The pick-up roller is directly connected to the sector gear, whose rotation is forcibly stopped by the gear stopper; when the pick-up solenoid is activated, the clutch mechanism is engaged by the solenoid action and the sector gear is driven; when it has completed one full turn its rotation is stopped again by the gear stopper. The paper drawn out by the pick-up roller pushes against the top of form sensor lever and the paper top position/absence of paper is detected by sensing the motion of the lever.

2.2.2 Paper Registration

When paper picked up from the multi-purpose sheet feeder (MPF) pushes against the top of form sensor actuator, the registration sensor lever is caused to turn, and the photo sensor detects this motion. When this signal from the sensor is detected the paper feed roller is stopped temporarily by the clutch. The paper is fed to the nip point between the paper feed roller and the pinch roller in the multi-purpose sheet feeder, and the skew of the paper is corrected by pushing the leading edge of the paper against the nip point. When the paper feed roller starts to be rotated again when it is released by the clutch, paper with the leading edge correctly aligned, is fed by the paper feed roller and is transported to the transfer roller.

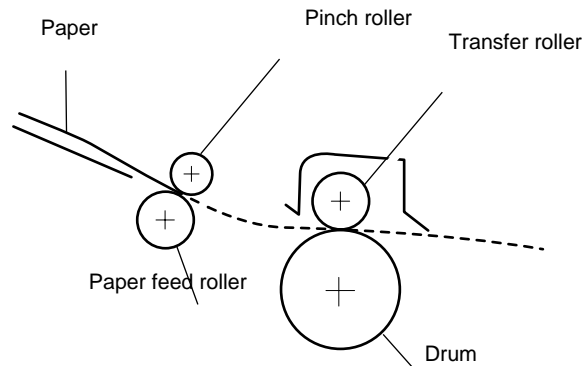

Clutch mechanism (engaged/released by the solenoid assembly)
Released when the solenoid is ON and engaged when the solenoid is OFF.

Fig. 2.20

2.2.3 Paper Eject

The completion of paper eject is detected in the following manner:

- (a) When the leading edge of the paper pushes down the eject sensor actuator located in the fixing unit, the photo sensor (photo interrupter) is opened and detects the start of paper eject.
- (b) When the trailing edge of the paper has passed through the paper eject sensor actuator, the photo sensor is closed and the completion of paper eject is recognized.

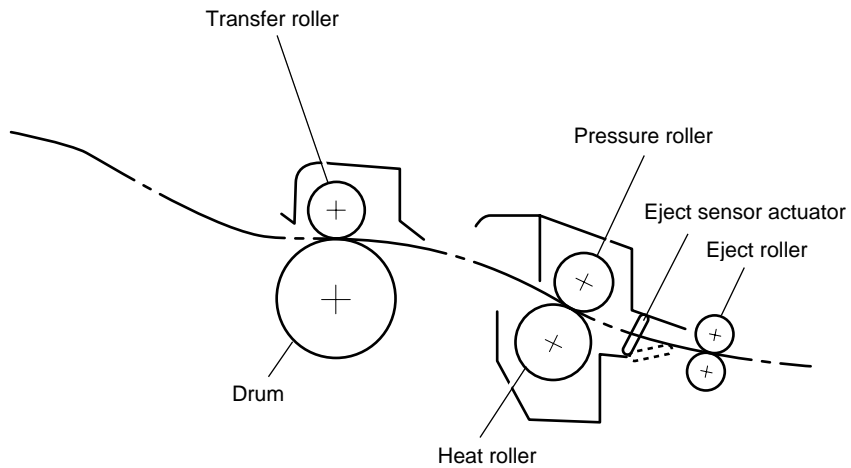

Fig. 2.21

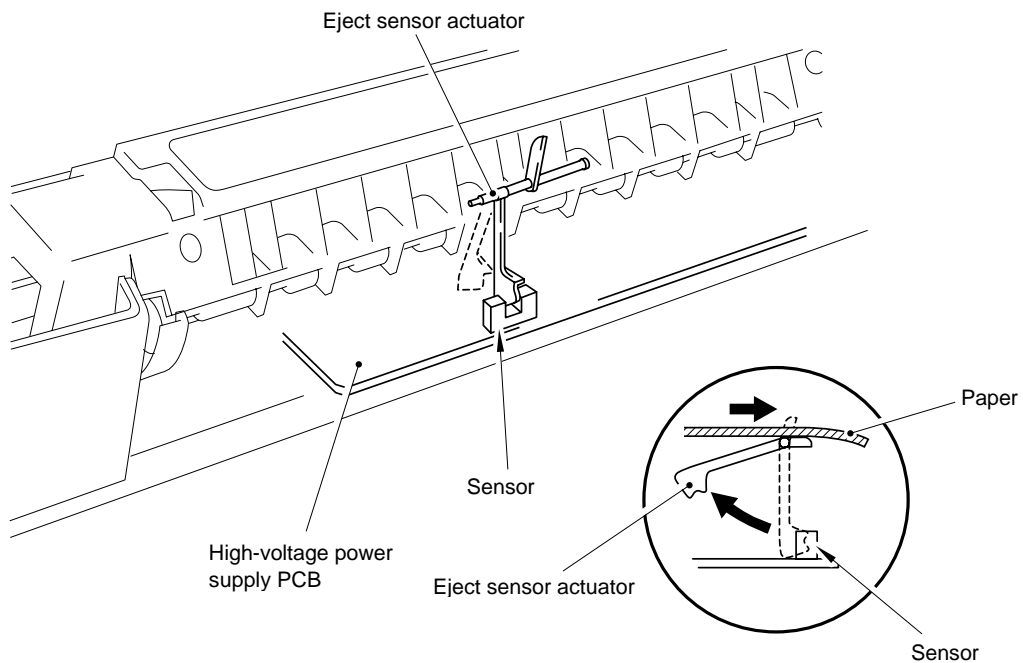

Fig. 2.22

2.3 Sensors

2.3.1 Cover Sensor

Detects opening and closing of the top cover.

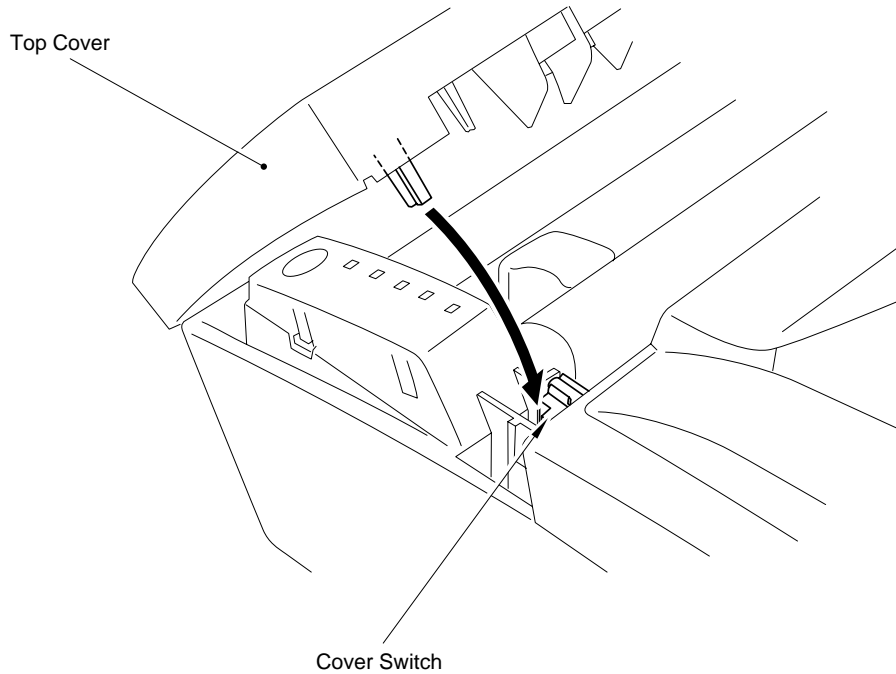

Fig. 2.23

2.3.2 Toner Empty Sensor

Detects if there is toner in the toner cartridge. It also detects whether or not the drum unit is installed. (The toner cartridge is installed in the drum unit).

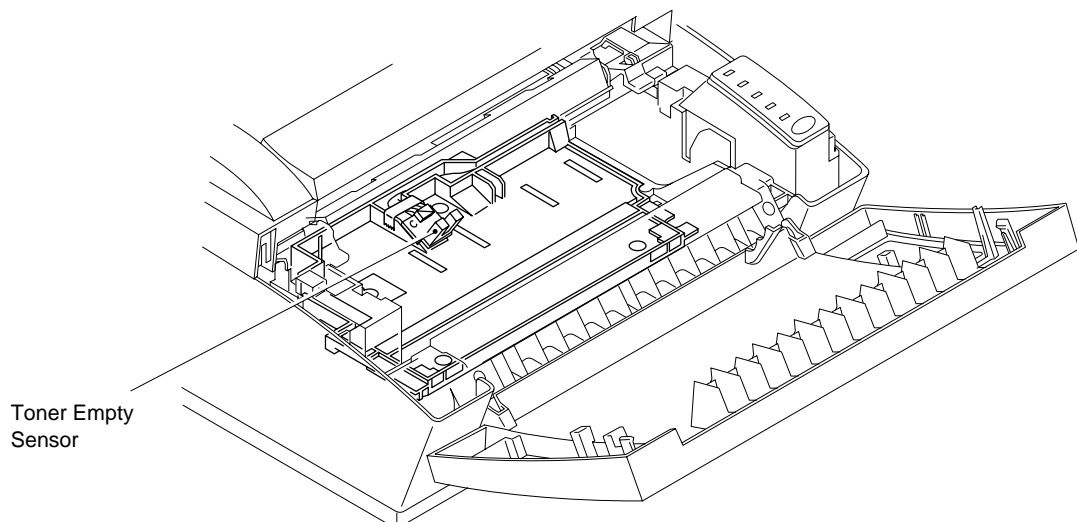

Fig. 2.24

2.4 Drum Unit

2.4.1 Photosensitive Drum

Generates the latent electrostatic image and develops the image on the drum surface.

2.4.2 Primary Charger

Forms a uniform charge on the drum surface.

- (1) Corona wire
Generates the ion charge on the drum.
- (2) Grid
Spreads the ion charge evenly over the drum surface.

2.4.3 Developer Roller

Develops the latent electrostatic image on the drum surface by the addition of the toner.

2.4.4 Transfer Roller

Transfers the toner image to the paper from the drum surface.

2.4.5 Cleaner Roller

Removes and recycles the toner remaining on the drum surface.

2.4.6 Erase Lamp

Discharges the electrostatic latent image on the drum.

2.5 Print Process

2.5.1 Charging

The drum is charged to approx. +1000V by an ion charge which is generated by the primary charger. The charge is generated by ionization of the corona wire, which has a DC bias from high-voltage power supply applied to it. The flow of the ion charge is controlled by the grid to ensure it is distributed evenly on the drum surface. The drum sleeve is regulated to approx. 280V by the voltage regulator.

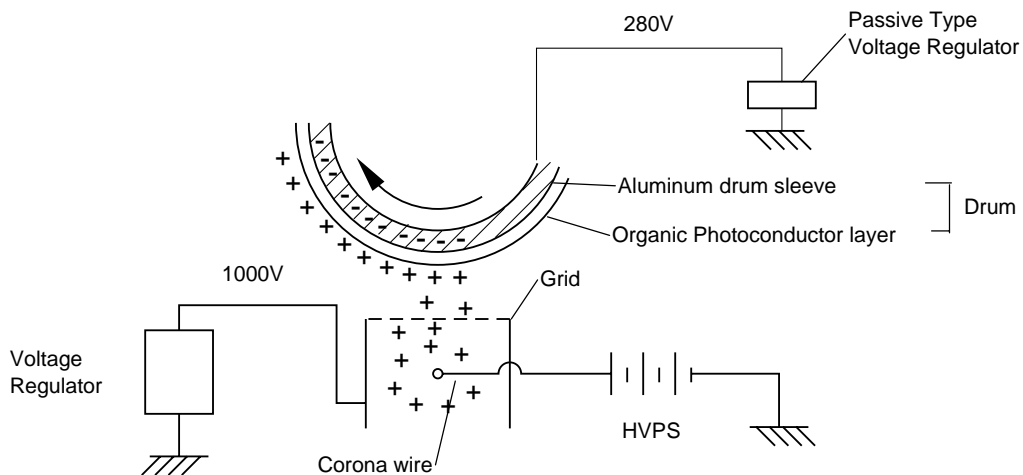

Fig. 2.25

The primary charge uses a corona wire, but since the drum is positively charged, only less than 1/10 of the usual quantity of ozone is generated compared with the negatively charged drum. The level of ozone expelled from the printer is therefore not harmful to the human body. Applicable safety standards have been complied with.

2.5.2 Exposure Stage

After the drum is positively charged, it is exposed to the light emitted from the laser unit.

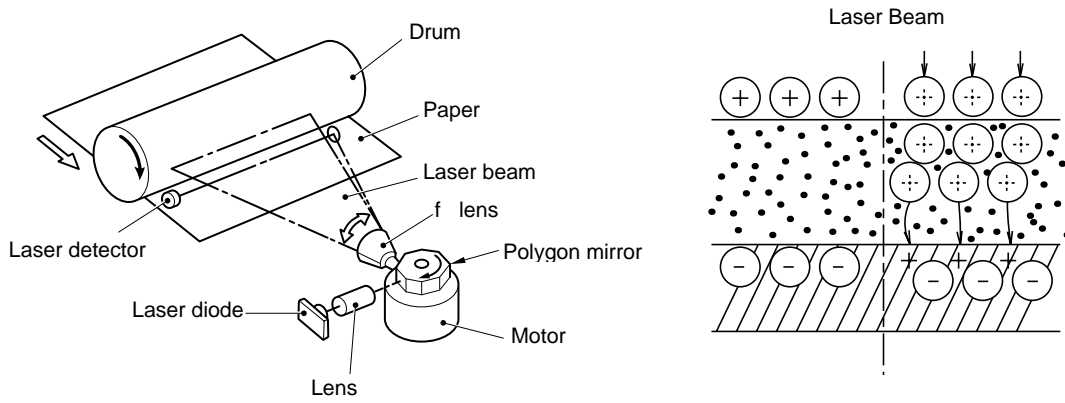

Fig. 2.26

The area exposed to the laser beam is the image to be printed. The surface potential of the exposed area is reduced forming the electrostatic image to be printed.

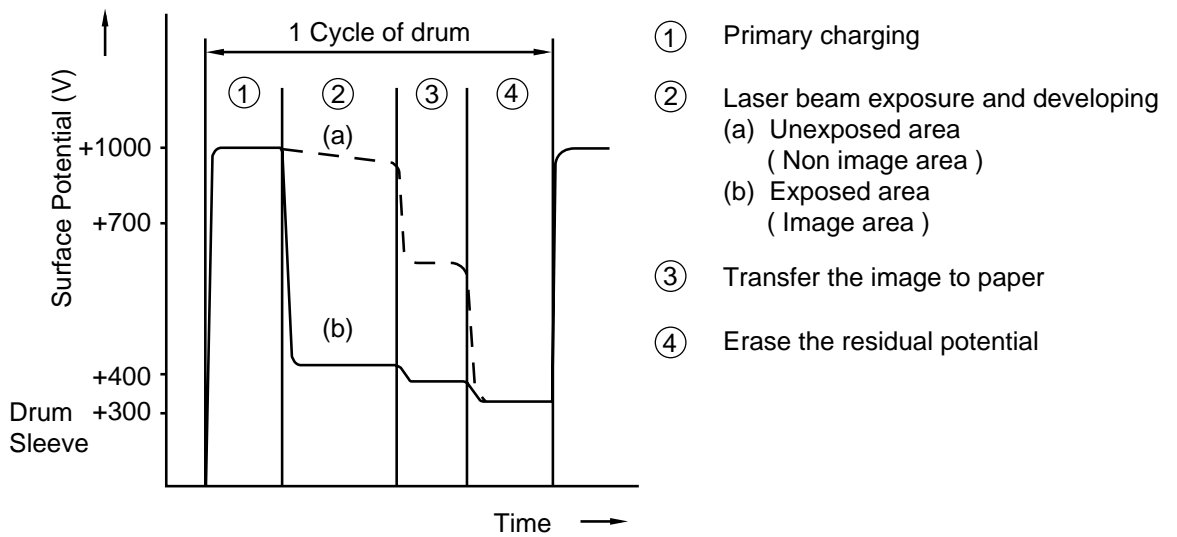

Fig. 2.27

2.5.3 Developing

Developing causes the toner to be attracted to the electrostatic image on the drum so as to transform it into a visible image.

The developer consists of a non-magnetic toner. The development roller is made of conductive rubber and the supply roller which is also made of conductive sponge rotate against each other. The toner is charged and carried from the supply roller to the development roller. The toner adheres to the development roller and is conveyed to the drum at an even thickness controlled by the blade. The toner is nipped between the development roller and the drum and developed onto the latent image on the drum. The electrostatic field between the drum and the development roller, which is DC-biased from the high-voltage power supply, creates the electrostatic potential to attract toner particles from the development roller to the latent image area on the drum surface.

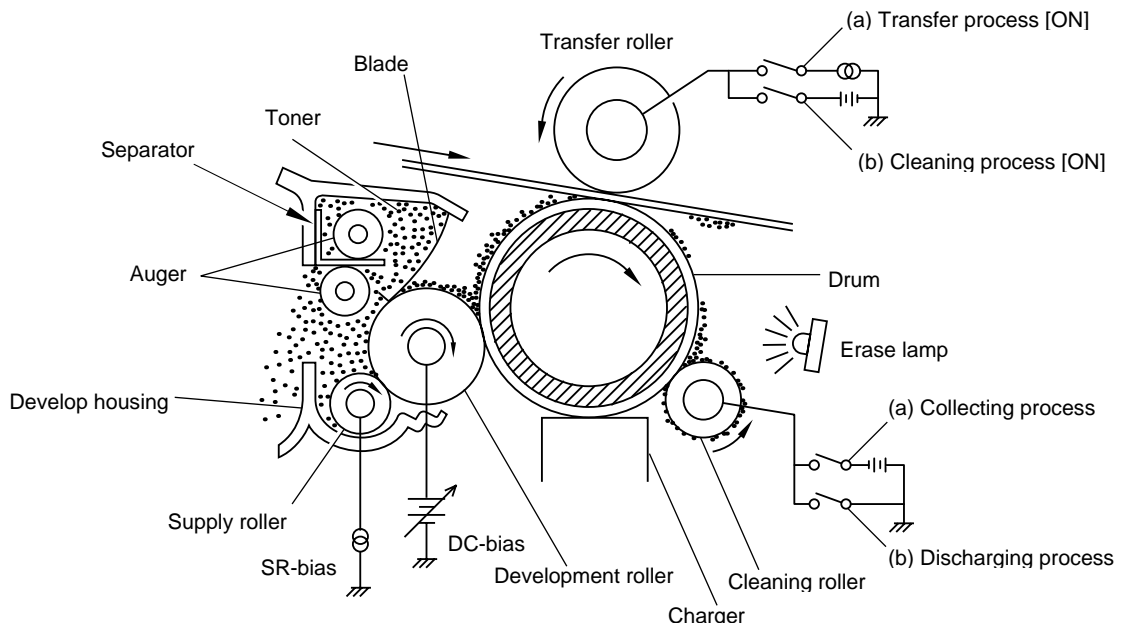

Fig. 2.28

2.5.4 Transfer

(a) Transfer process

After the drum has been charged and exposed, and has received a developed image, the toner formed is transferred onto the paper by applying a negative charge to the backside of the paper. The negative charge applied to the paper causes the positively charged toner to leave the drum, and adhere to the paper. As a result, the image is visible on the paper.

(b) Cleaning process of transfer roller

If the toner is not transferred onto the paper perfectly, it is possible that there may be residual toner on the drum which will adhere to the transfer roller. The transfer voltage charges to a positive voltage during non-printing rotation of the drum. Therefore the transfer roller is cleaned by returning the positive charged toner adhered on the transfer roller onto the photo-conductive drum.

2.5.5 Drum Cleaning Stage

In the image transfer stage, not all the toner on the photosensitive drum is transferred onto the paper but some remains on the drum. In the drum cleaning stage, the drum surface is cleaned by the cleaning roller, so that residual toner on the drum surface is removed and collected on the cleaning roller itself. The residual toner on the cleaning roller will be discharged to the drum when starting or non-printing time. The toner will be collected by the developing roller and reused (for further developing).

2.5.6 Erasing Stage

Before the cleaning stage, the drum surface is exposed to the light emitted from the erase lamp. (LED lamp) This stage prepares the drum by decreasing its surface voltage uniformly, ready to receive uniform charge in the primary charging stage.

2.5.7 Fixing Stage

An image transferred on paper by static electricity is fixed by heat and pressure when passing through the heat roller and the pressure roller in the fixing unit. The thermistor ASSY keeps the surface temperature of the heat roller constant by detecting the surface temperature of the heat roller and turning on or off the halogen heater lamp. The cleaner ASSY HR eliminates toner stains on the surface of the heat roller.

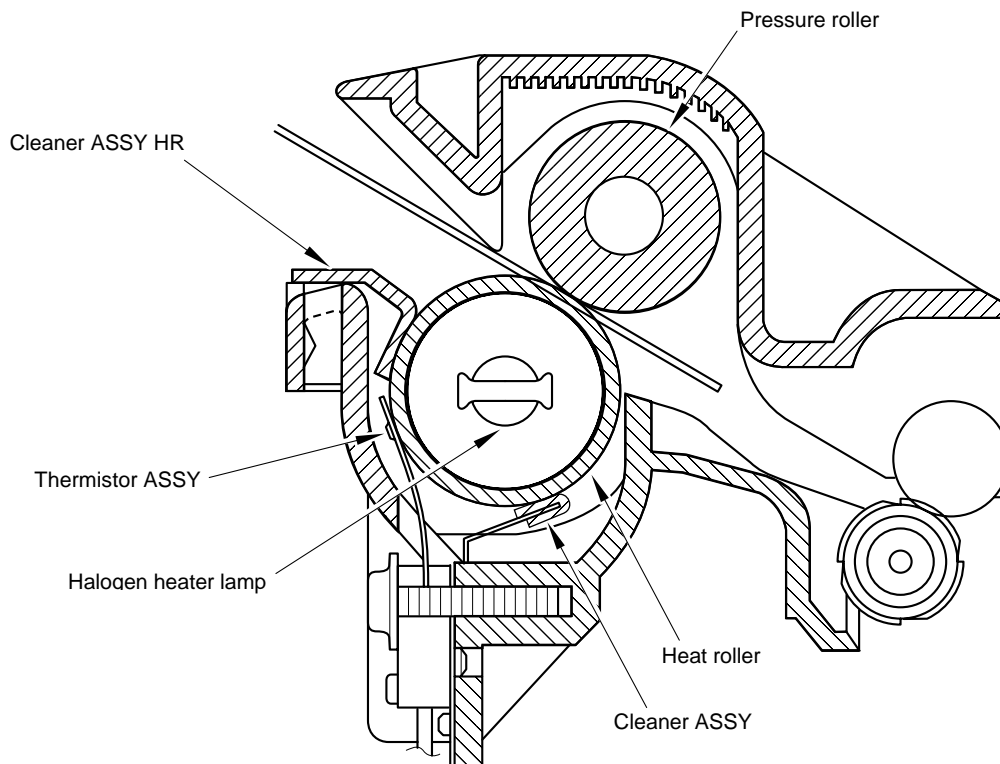

Fig. 2.29

CHAPTER III DISASSEMBLY AND REASSEMBLY

1. SAFETY PRECAUTIONS

To avoid creating secondary problems by mishandling, be careful to follow the following precautions during maintenance work.

- (1) Always turn off the power switch and unplug the power cord from the power outlet before accessing any parts inside the printer.
- (2) Be careful not to lose screws, washers, or other parts removed.
- (3) Be sure to apply grease to the gears and applicable positions specified in this chapter.
- (4) When using soldering irons or other heat-generating tools, take care not to accidentally damage parts such as wires, PCBs, and covers.
- (5) Before handling any PCBs, touch a metal portion of the equipment to discharge any static electricity charge on your body, or the electronic parts or components may be damaged.
- (6) When transporting PCBs, be sure to wrap them in the correct protective packaging.
- (7) Be sure to replace self-tapping screws correctly, if removed. Unless otherwise specified, tighten screws to the following torque values.

TAPTITE, BIND or CUP B

M3 : 7kgf • cm

M4 : 10kgf • cm

TAPTITE, CUP S

M3 : 8kgf • cm

SCREW

M3 : 7kgf • cm

M4 : 8kgf • cm

- (8) When connecting or disconnecting cable connectors, hold the connector bodies, but not the cables. If the connector has a lock, release the connector lock first to unlock it.
- (9) After a repair, check not only the repaired portion but also all connectors, also check that other related portions are functioning properly before operational checks.

2. DISASSEMBLY FLOW

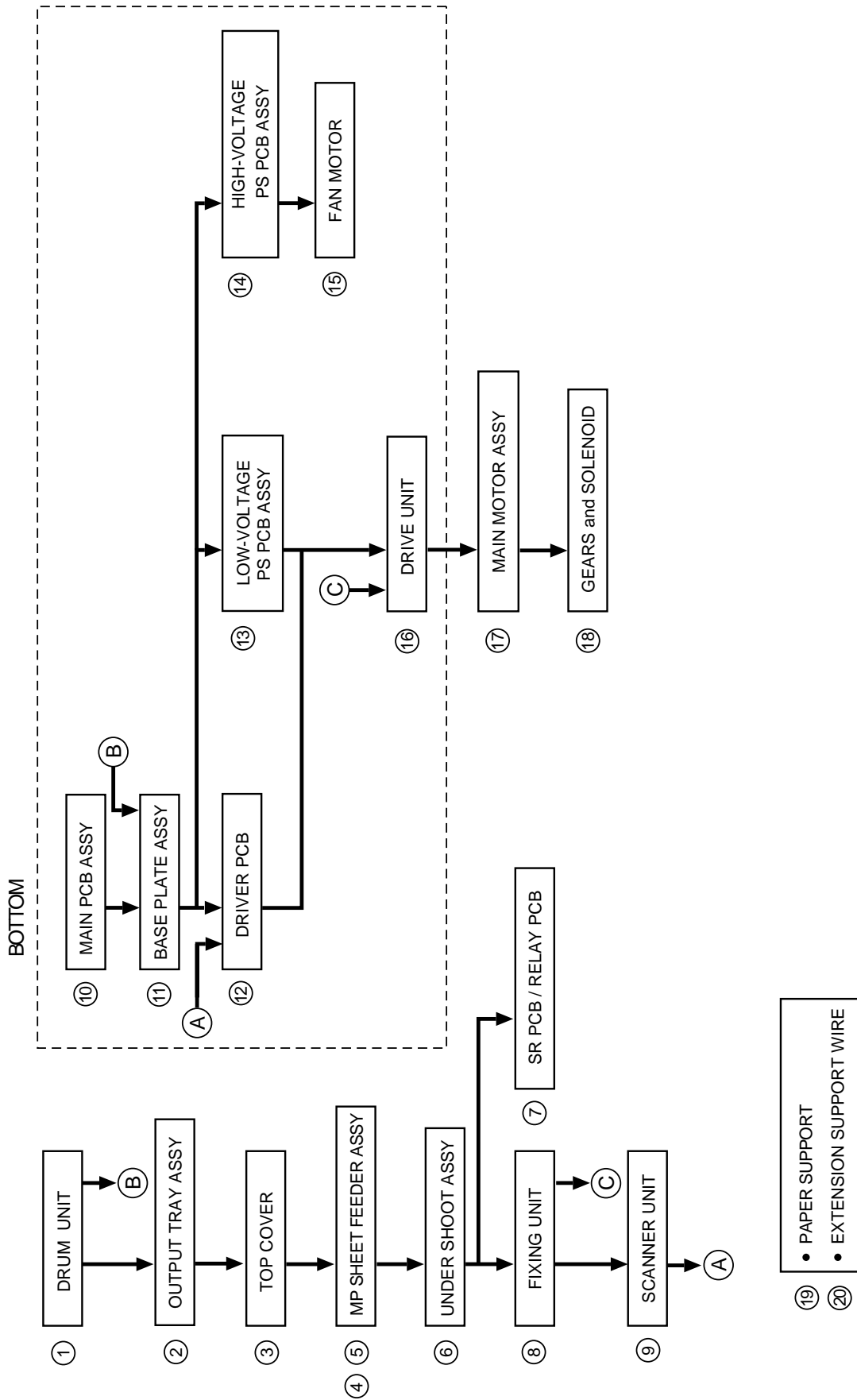

3. DISASSEMBLY PROCEDURE

3.1 Drum Unit

- (1) Open the top cover.
- (2) Lift out the drum unit.

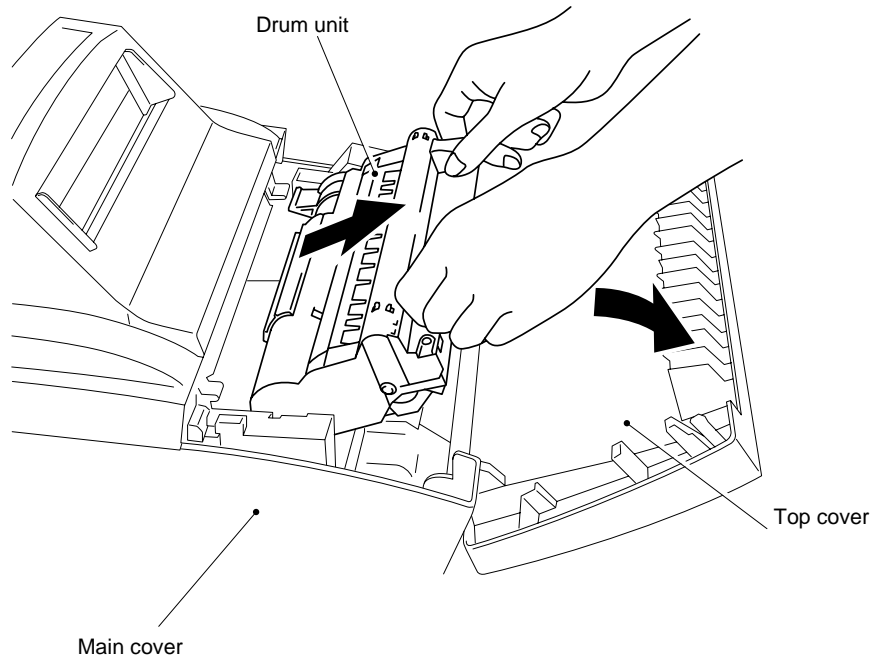

Fig. 3.1

3.2 Output Tray ASSY

- (1) Press the hinges at the left and right ends of the output tray inwards to release the output tray from the main cover.

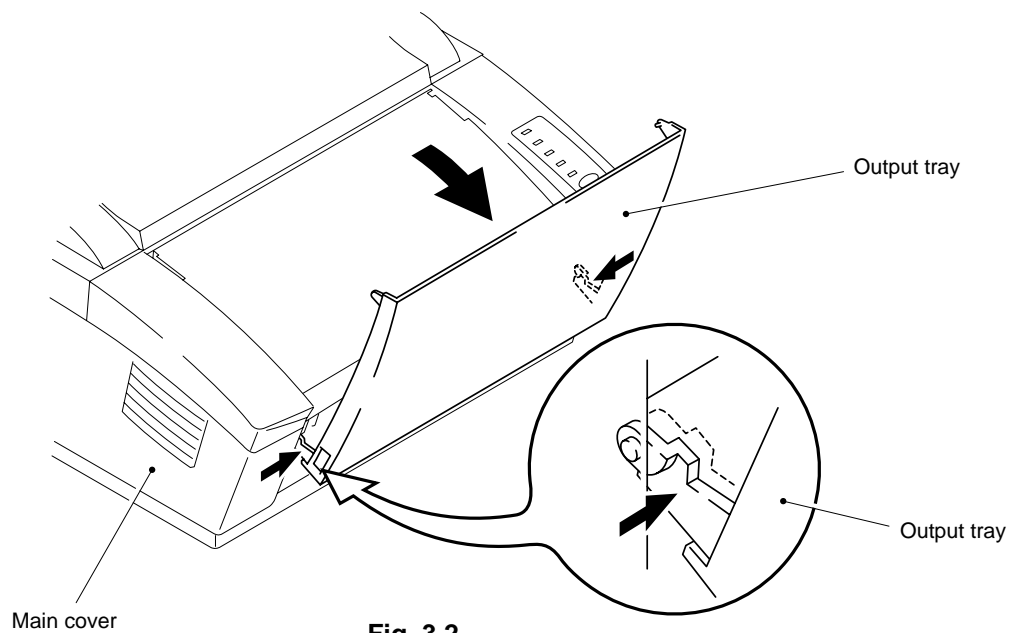

Fig. 3.2

3.3 Top Cover

- (1) Open the top cover.
- (2) Press the hinges at the left and right ends of the top cover inwards to release the top cover from the main cover.

Note: If it is impossible to release the top cover in the above way, press the side of the top cover (①) while pulling the side of the main cover (②).

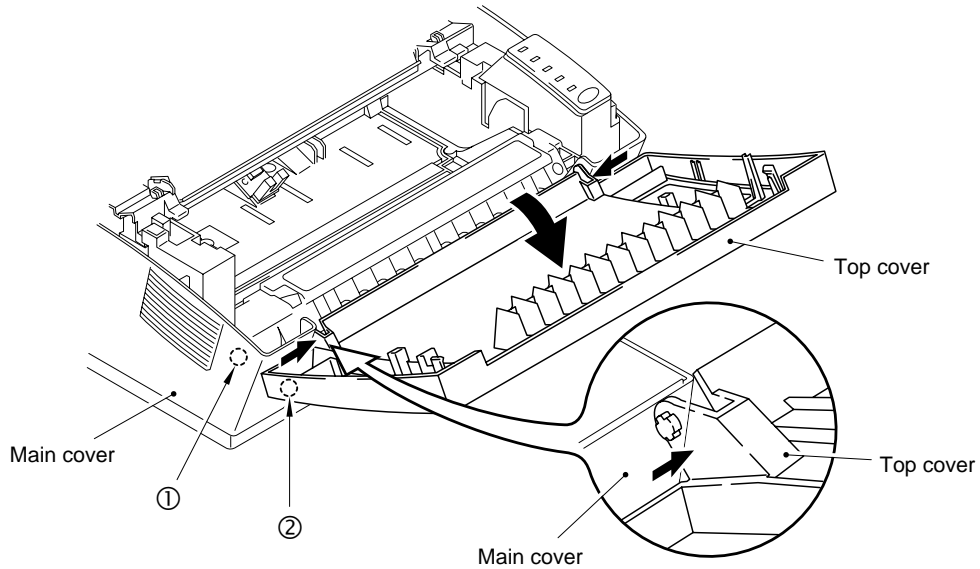

Fig. 3.3

3.4 MP Sheet Feeder 1 ASSY

Note: When disassembling the MP sheet feeder ASSY, the grease which smears your fingers will stick to the separation pad or the paper pick-up roller, and then spread to the paper and the drum unit. It might cause to appear black spots on the printing page.

- (1) Slide the upper portion of MP sheet feeder 1 toward you and remove it.

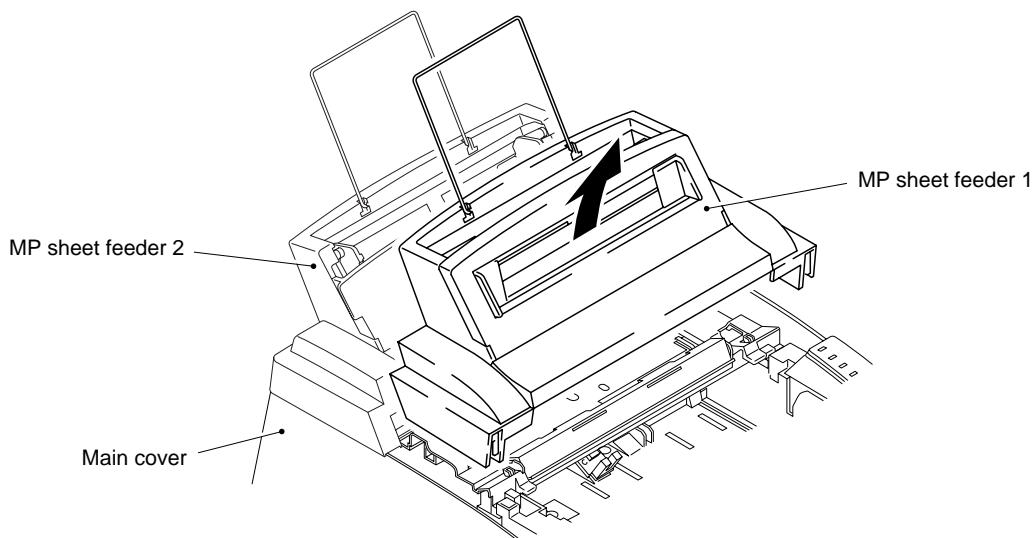

Fig. 3.4

- (2) Raise the pick-up roller cover (①) and remove it (②).
- (3) Remove the MP feeder cover (③).

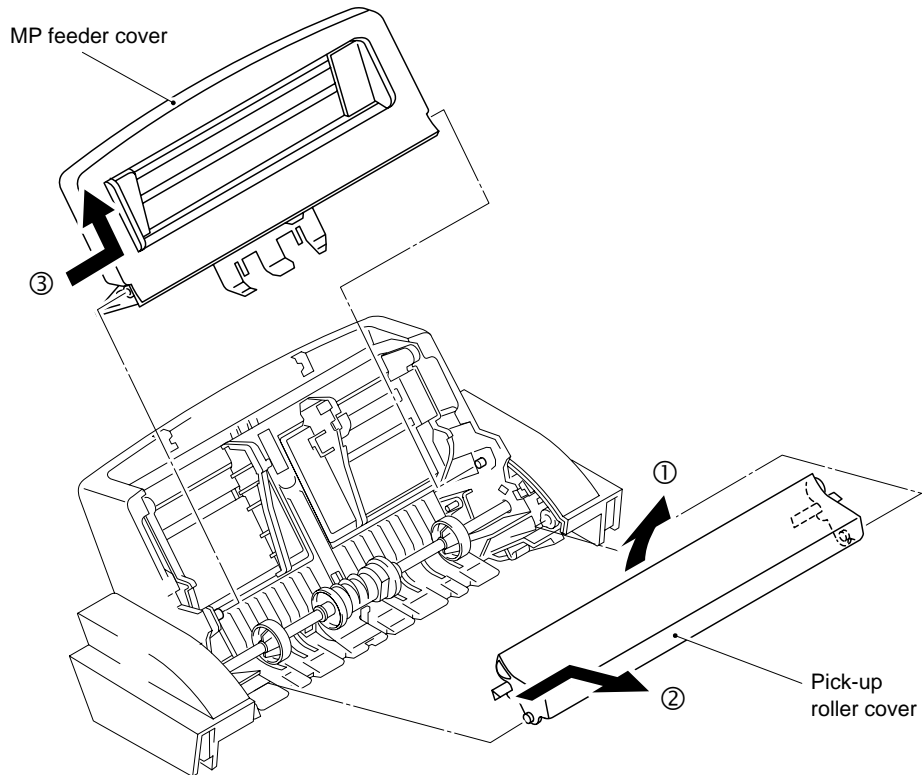
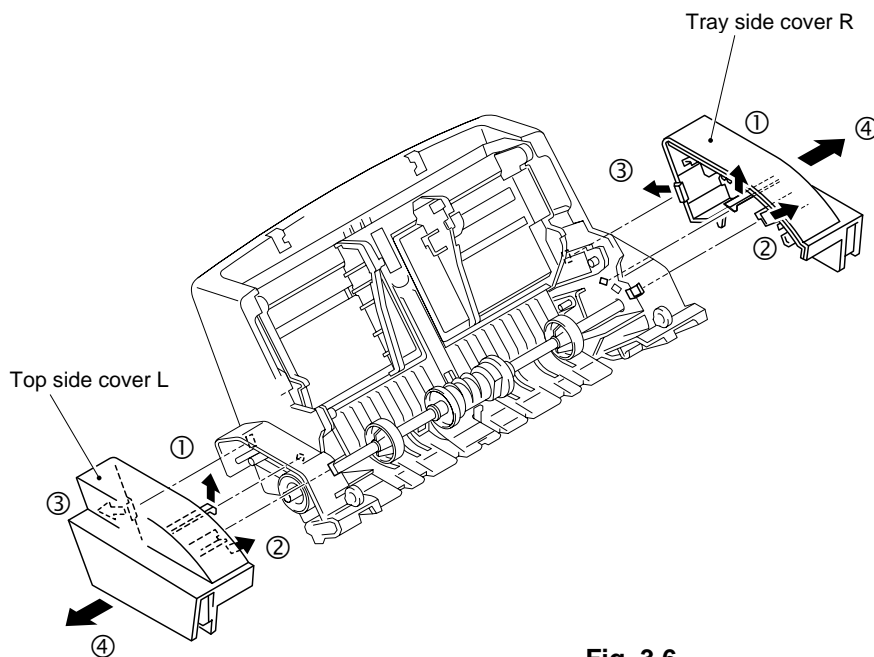

Fig. 3.5

- (4) Remove the tray side covers R and L by releasing the three hooks inside each of the covers as the following order.



<Releasing procedure>

1. Release the hook ① by hands.
2. Release the hook ② by using a screwdriver.
3. Release the hook ③ by using a screwdriver.
4. Pull out the tray side covers straight.

Fig. 3.6

- (5) After removing the sector gear, paper feed bearing, and bearing 6, take off the paper pick-up roller unit.

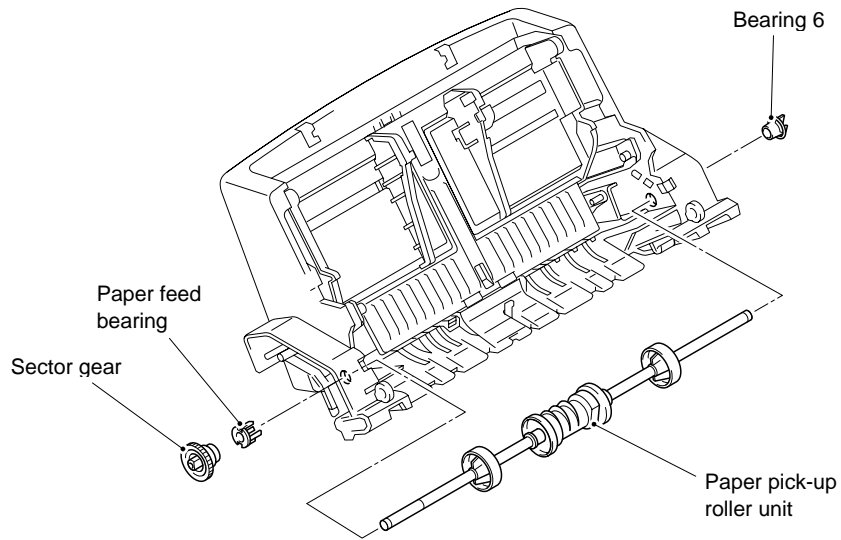

Fig. 3.7

- (6) Raise the pressure plate toward you and press both sides of the pad inward to release it by pressing the separation pad holder. Then take off the spring.

Note: If it is impossible to release the pressure plate in the above way, press the side of the pressure plate (①) while pulling the side of the sheet feeder (②).

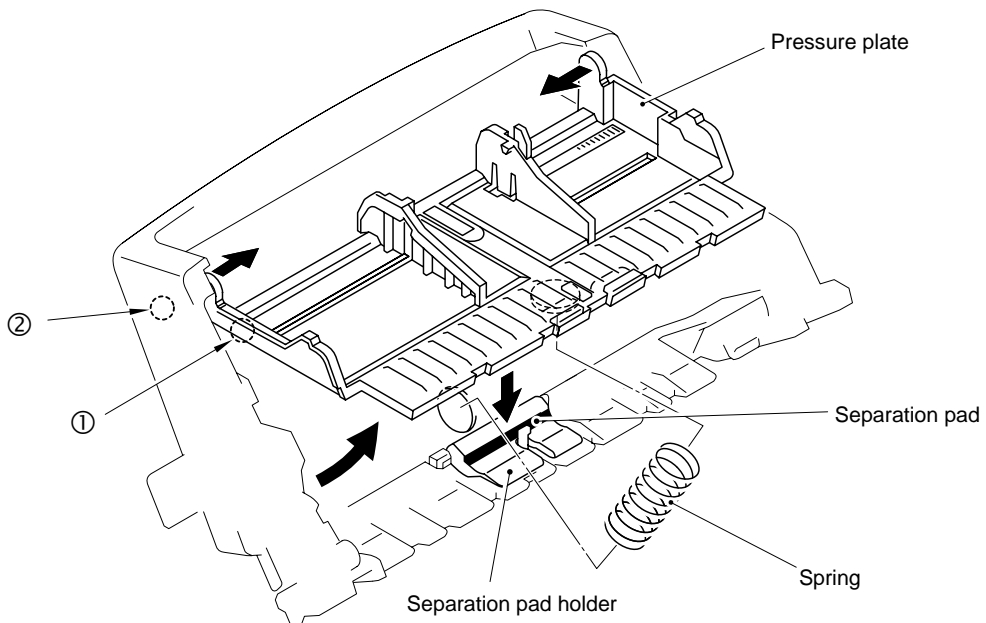

Fig. 3.8

Note: Be sure to replace the regist sensor actuator film together whenever replacing the regist sensor actuator.

3.5 MP Sheet Feeder 2 ASSY

- (1) Remove the four screws.
- (2) Disassemble any other parts of MP sheet feeder 2 in the same way as described for MP sheet feeder 1.

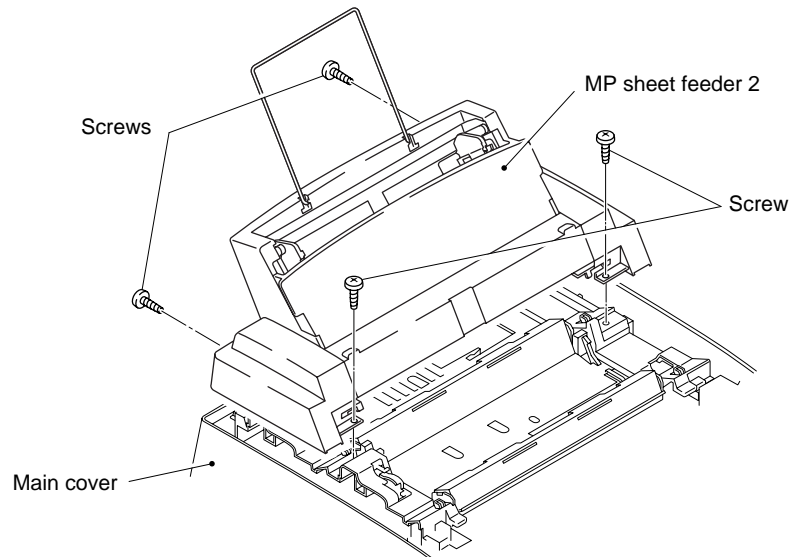

Fig. 3.9

3.6 Under Shoot ASSY

- (1) Disconnect the two cable harnesses from the relay PCB.

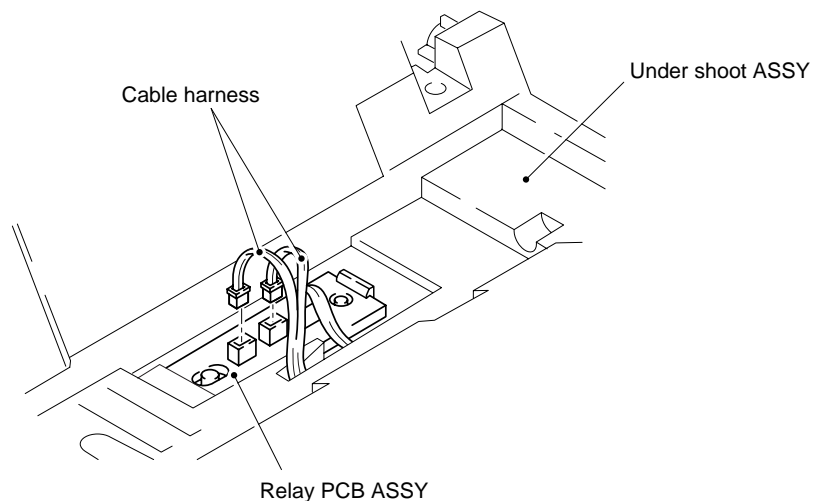

Fig. 3.10

- (2) Remove the two screws.
- (3) Lift the rear portion of the under shoot assy to remove it.

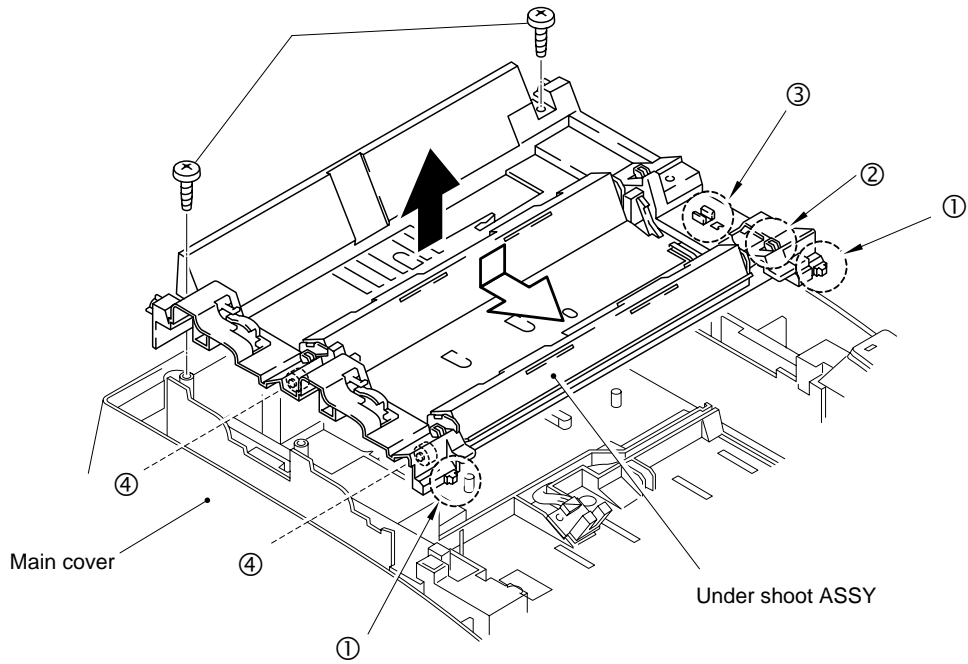

Fig. 3.11

Note: Follow the number above in order when assembling.

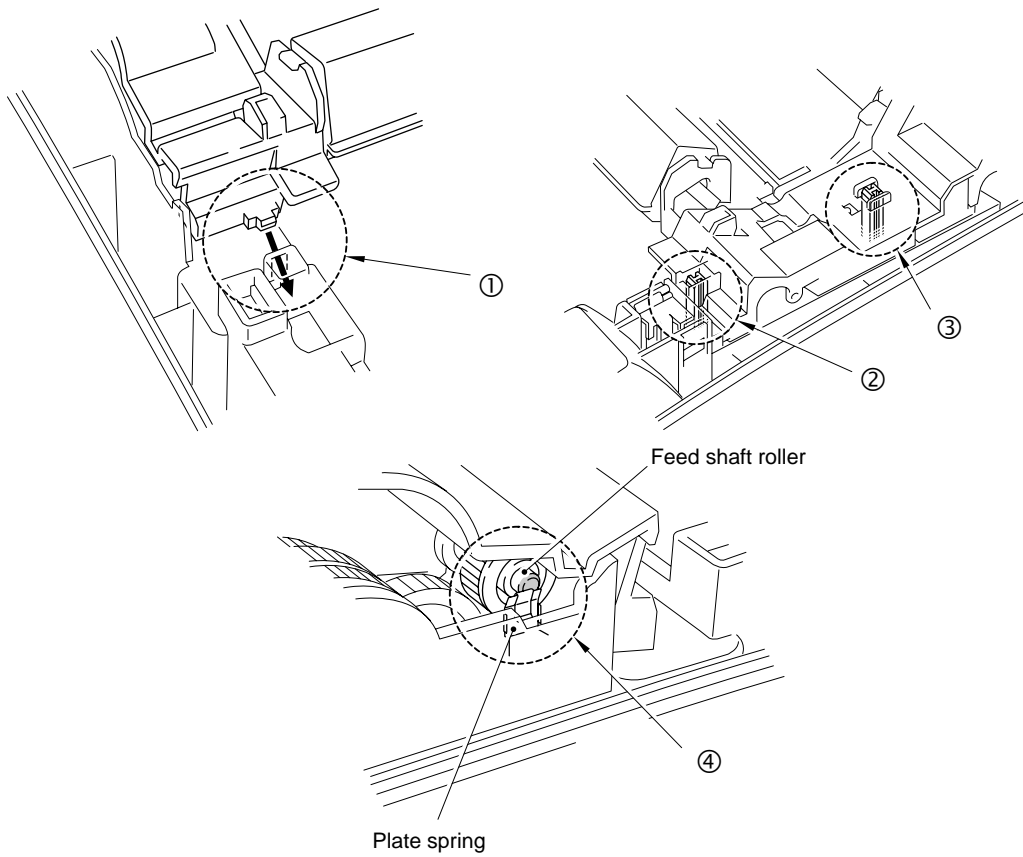

Fig. 3.11.1

3.7 SR PCB / Relay PCB

- (1) Remove the SR protect sheet.
- (2) Disconnect the connector of the SR harness ASSY connecting the SR PCB and the driver PCB and remove the high-voltage cover.

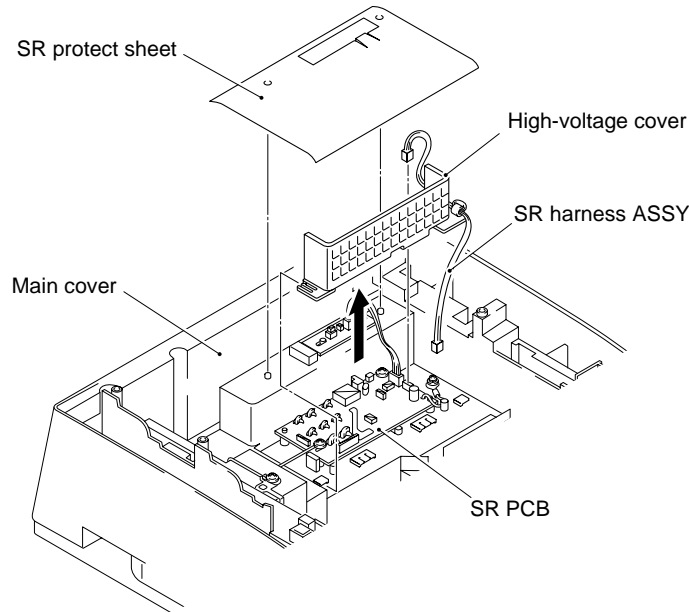

Fig. 3.12

- (3) Disconnect the connector of the relay harness ASSY connecting the SR PCB and the relay PCB and remove the two screws on the SR PCB, and remove the SR PCB.
- (4) Remove the relay PCB.
- (5) Remove the two screws, and remove the electrode SR1, SR2.

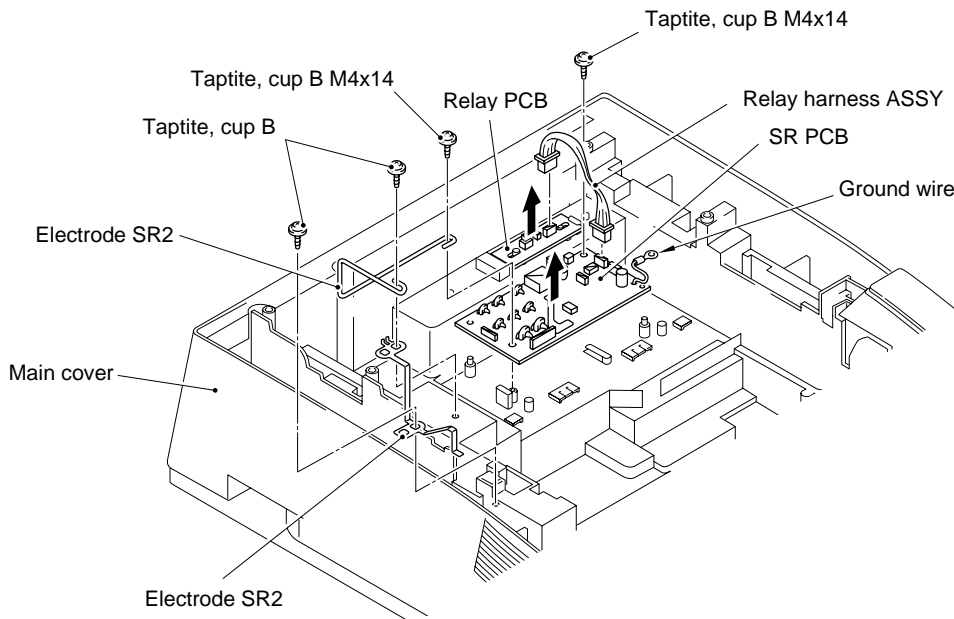

Fig. 3.13

3.8 Fixing Unit

- (1) Remove the two screws.
- (2) Lifting the fixing unit, disconnect the two heater harnesses and the thermistor connector on the EL PCB.

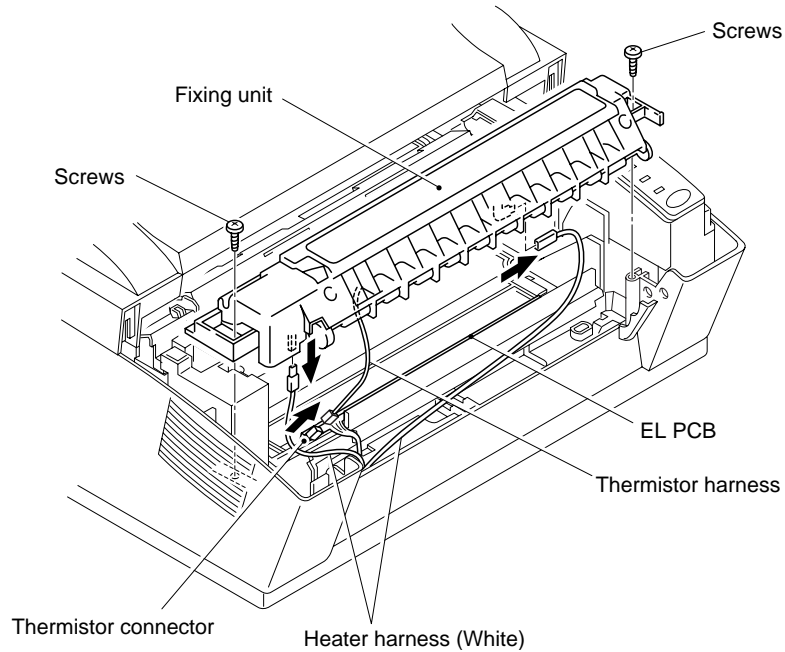

Fig. 3.14

- (3) Unhook the harness of the thermistor ASSY from the hook of the fixing unit.
- (4) Remove the screw.
- (5) Remove the thermistor ASSY.
- (6) Remove the cleaner ASSY.

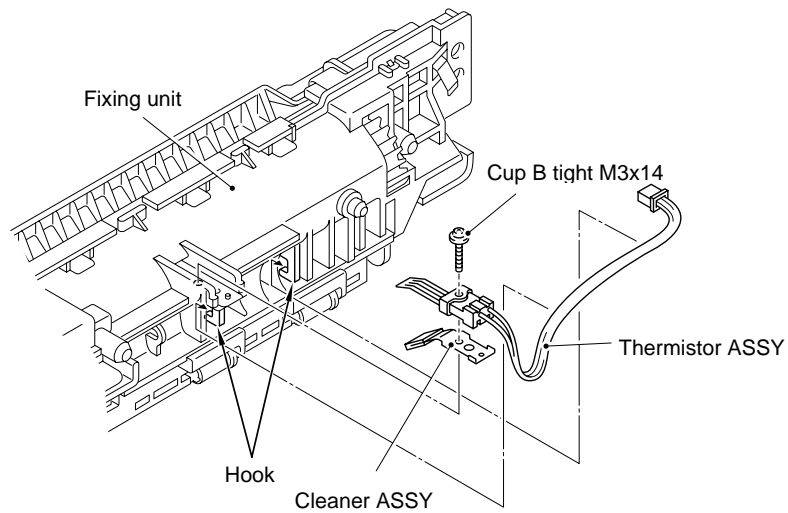

Fig. 3.15

Note: Follow instructions below when installing the thermistor in the fixing unit.

- Place the cleaner felt of the cleaner ASSY under the heat roller.
- Place the end of the thermistor on the heat roller.
- Insert the boss1 of the thermistor into the hole of the fixing unit frame.
- Do not place the thermistor on the boss2 of the fixing unit frame.

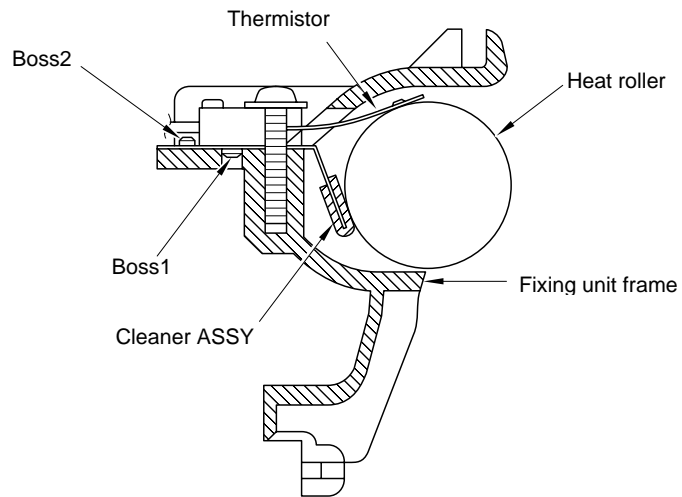

Fig. 3.16

- (7) Remove the two screws.
- (8) Open the fixing unit cover along the open side of the fixing unit cover.

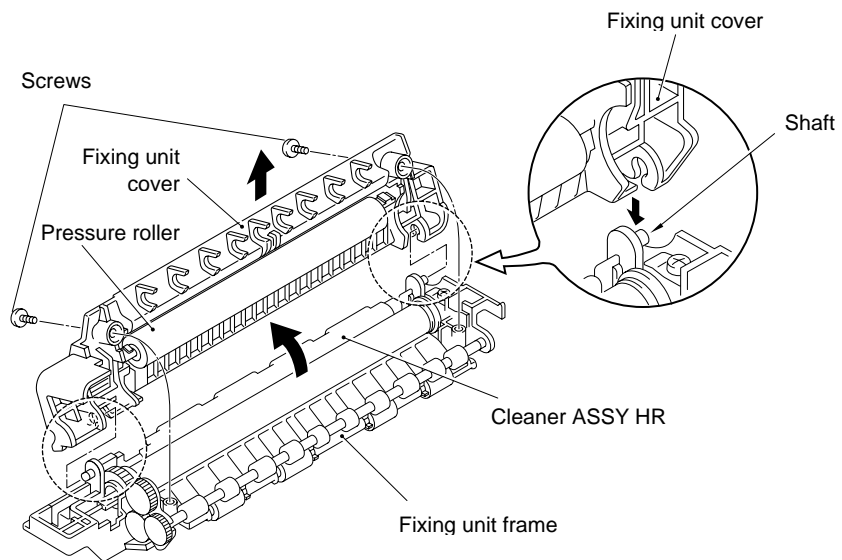

Fig. 3.17

- (9) Release the cleaner lock from the cleaner ASSY HR.
- (10) Remove the cleaner ASSY HR from the fixing unit.

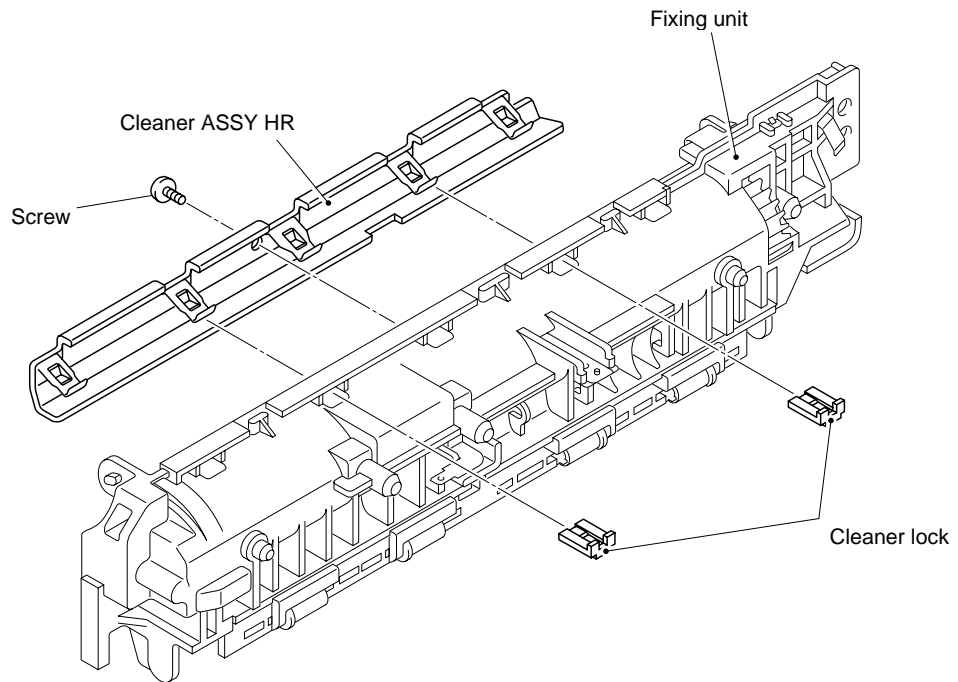

Fig. 3.18

- (11) Release the right side of the paper eject roller shaft.
- (12) Remove the four eject pinch rollers and the pinch springs from the fixing unit frame. Then, remove the pinch spring from each pinch roller.

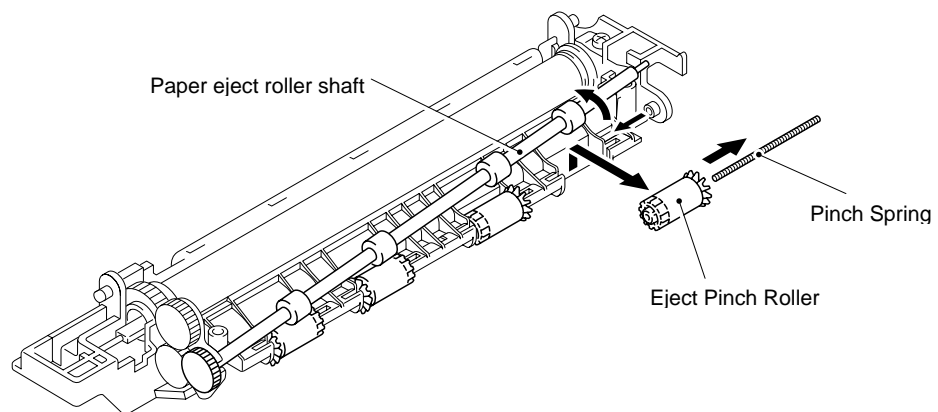

Fig. 3.18a

Note: Follow instructions below when installing the cleaner ASSY HR.

- Put the cleaner ASSY HR on the heat roller.
- Rotate the hook of the cleaner ASSY HR as shown in the figure to fit it into the fixing unit frame.
- Insert the cleaner lock into the fixing unit frame.

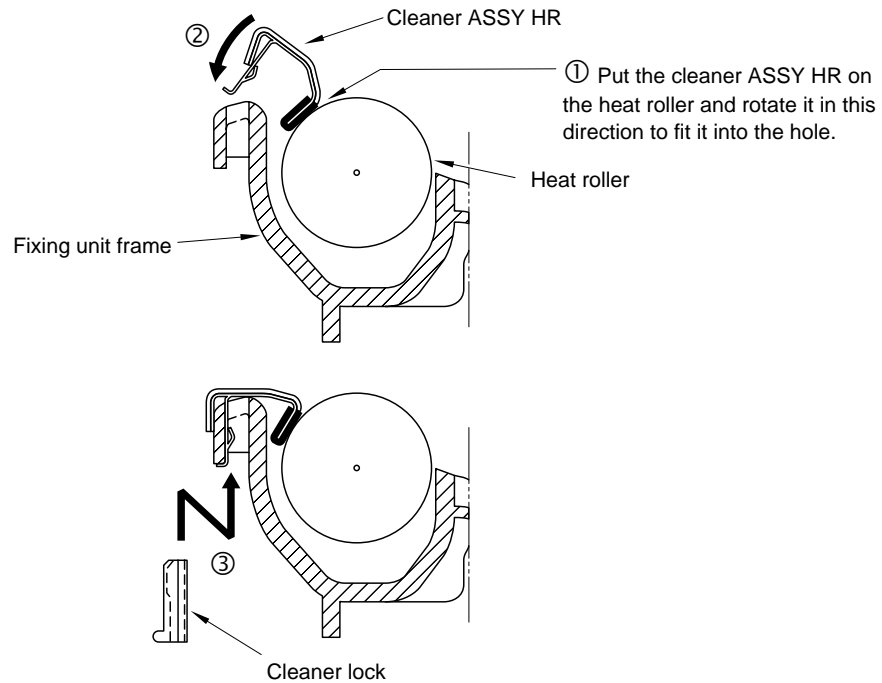

Fig. 3.19

- (13) Remove the bind B tight 3 x 10 screw securing the connector plate.
- (14) Remove the connector plate from the fixing unit frame and loosen the other bind B tight 3 x 10 screw securing the fixing unit cover.
- (15) After removing the idle gear 16 from the fixing unit frame, the heat roller can be removed. You can then remove the halogen heater lamp from the heat roller.

Note: Never touch the surface of the halogen heater lamp.

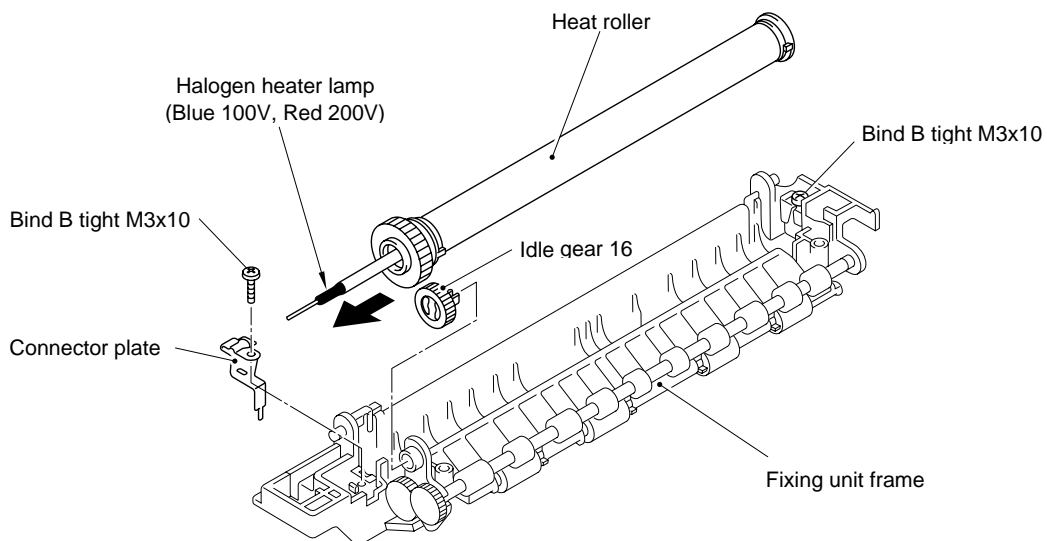

Fig. 3.20

3.9 Scanner Unit

- (1) Remove the three screws.
- (2) Lift out the scanner unit.

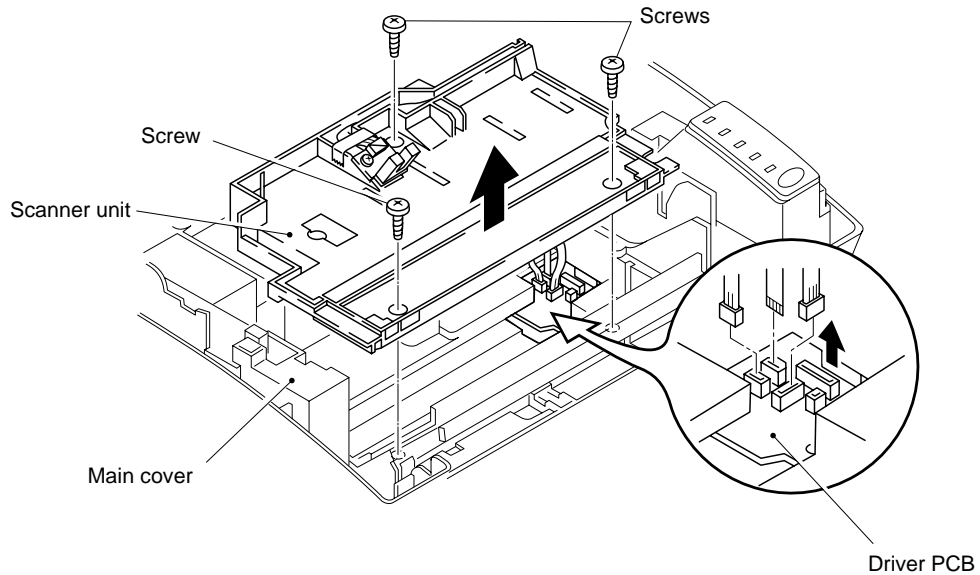

Fig. 3.21

- (3) Disconnect the three connectors from the driver PCB.
- (4) Remove the screw and the tape, and lift the toner sensor PCB from the scanner unit.

Note: Never touch the inside of the scanner unit or the mirror when disassembling or reassembling. If there is any dirt or dust on the mirror, blow it off.

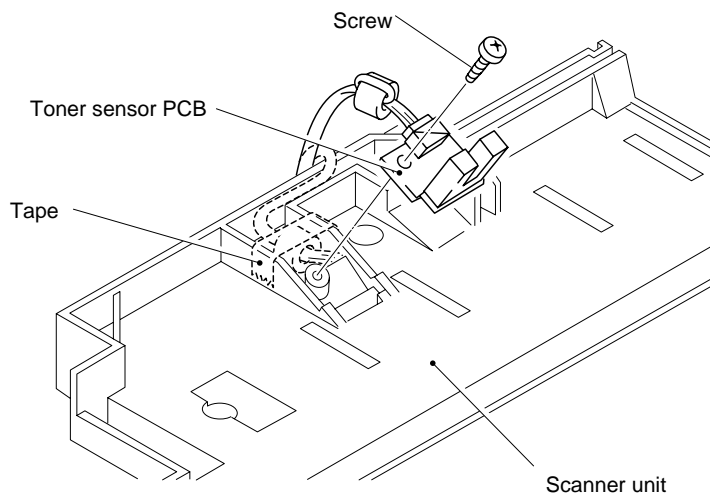

Fig. 3.22

- (5) Turn the scanner unit upside down and remove the screw to release the toner sensor harness.

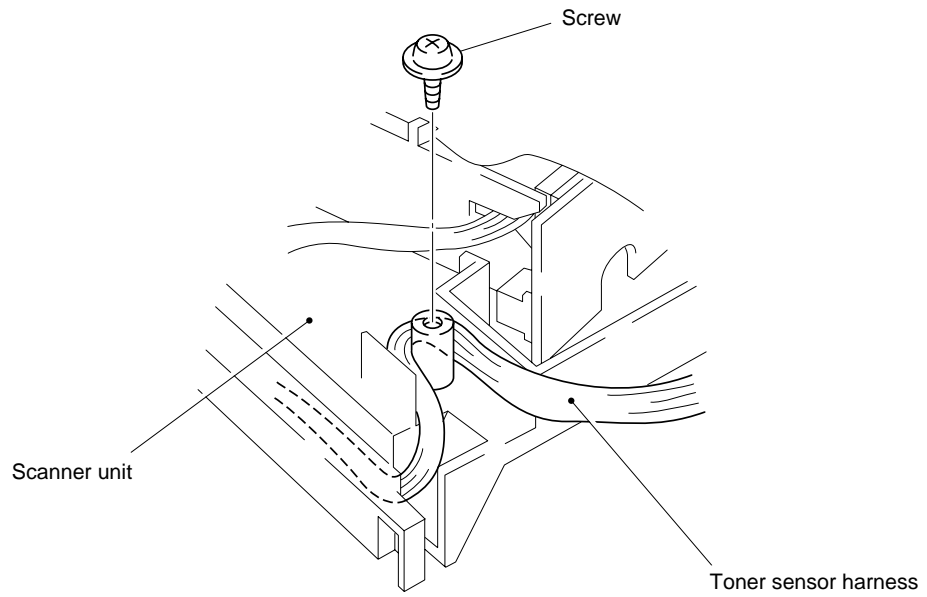

Fig. 3.22-1

3.10 Main PCB ASSY

- (1) Remove the four screws.
- (2) Hold the hooks at left and right to pull out the main PCB ASSY.

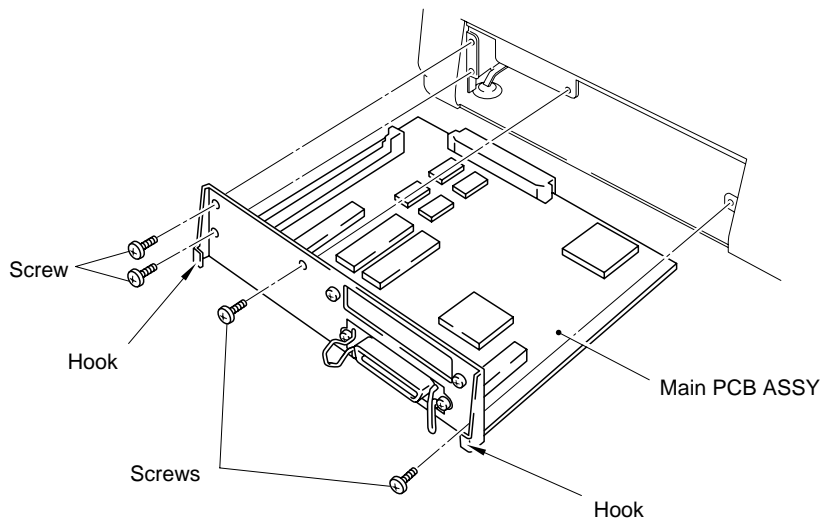

Fig. 3.23

3.11 Base Plate ASSY

Note: Prior to turning the printer upside-down, ensure that the drum unit has been removed from the printer.

- (1) Turn the printer upside down.
- (2) Remove the five M4 and four M3 self tapping screws and one screw.

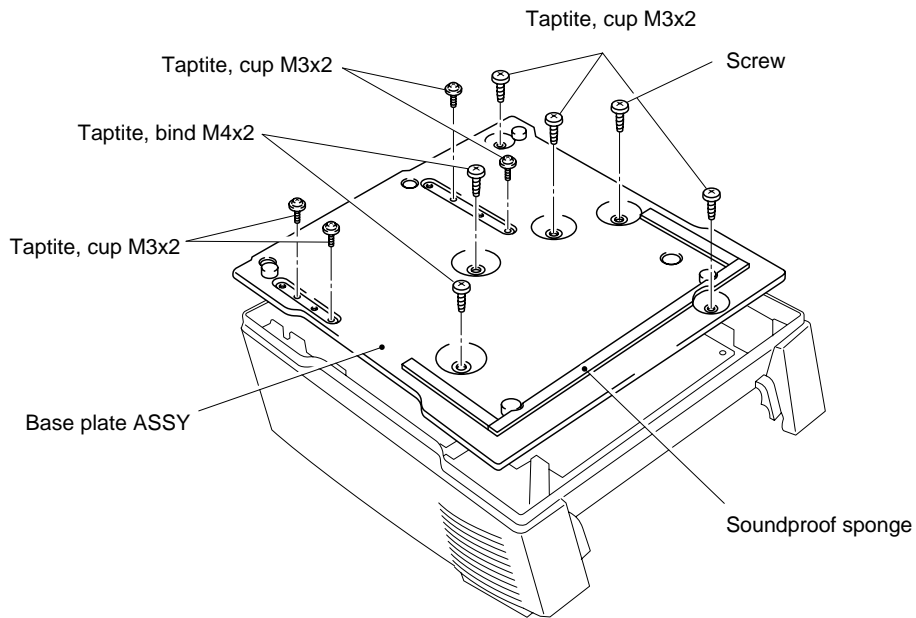

Fig. 3.24

- (3) Lift the base plate ASSY and remove the grounding screw.

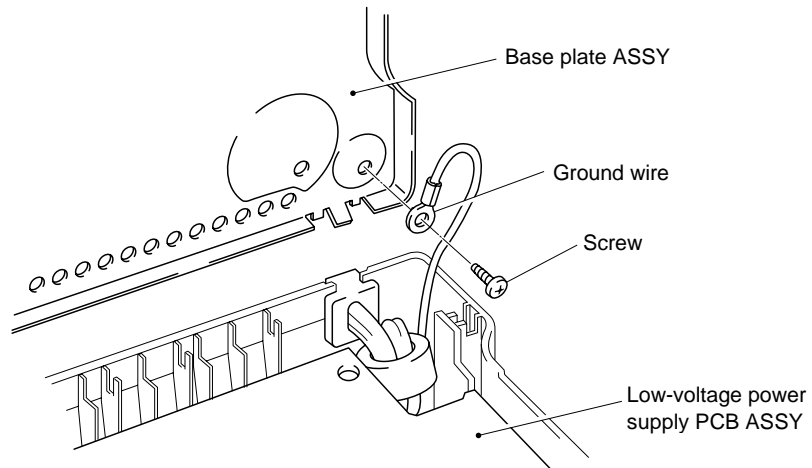

Fig. 3.25

Note: See the Fig. 3.26 about the position installing the dumping material and the soundproof sponge A,B.

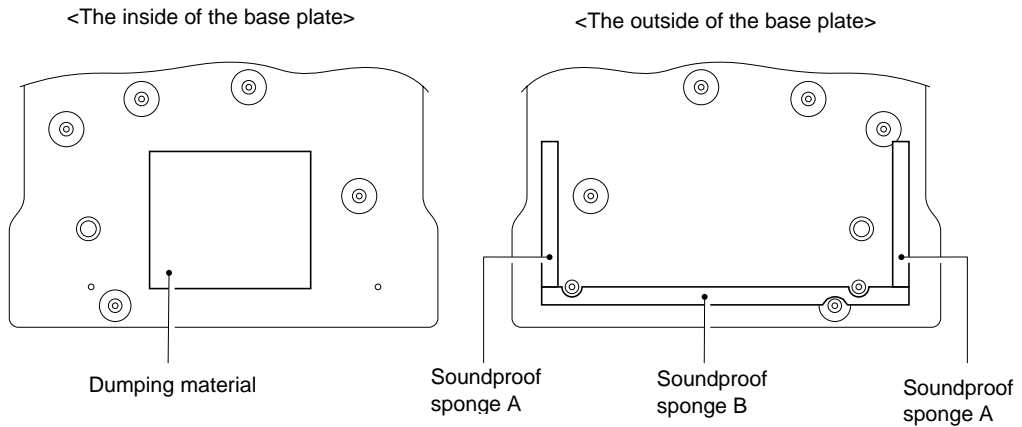

Fig. 3.26

3.12 Driver PCB ASSY

- (1) Remove the screw securing the driver PCB ASSY. (Slide the PCB A from underneath the main shield.)

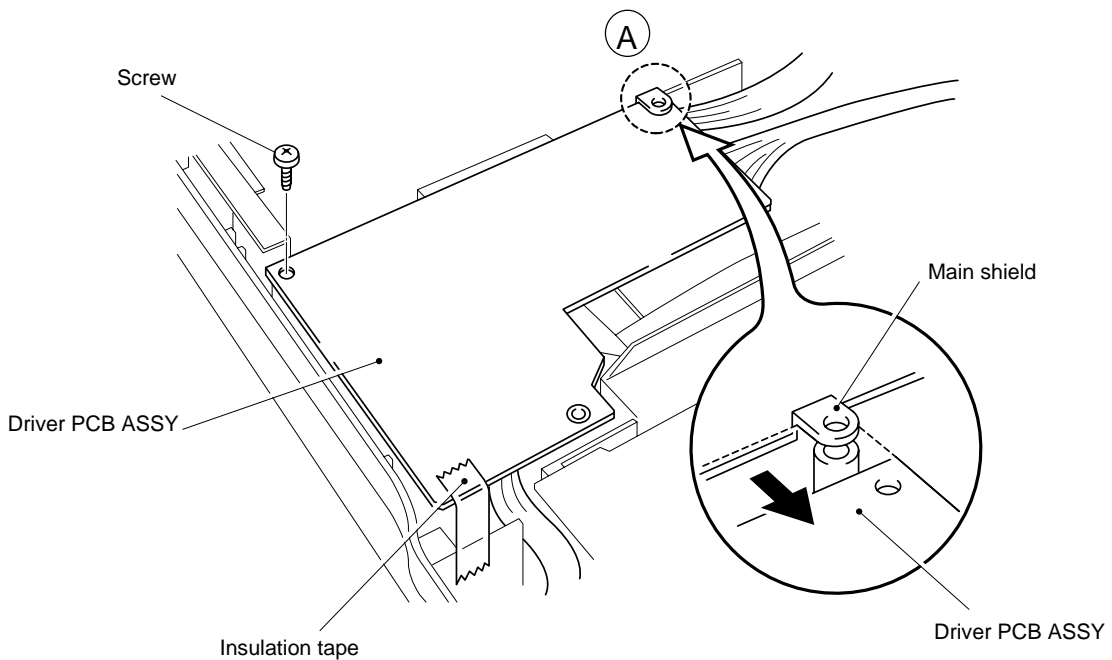

Fig. 3.27

- (2) Disconnect the eleven connectors from the PCB. (Three connectors have already been disconnected when removing the scanner unit.)

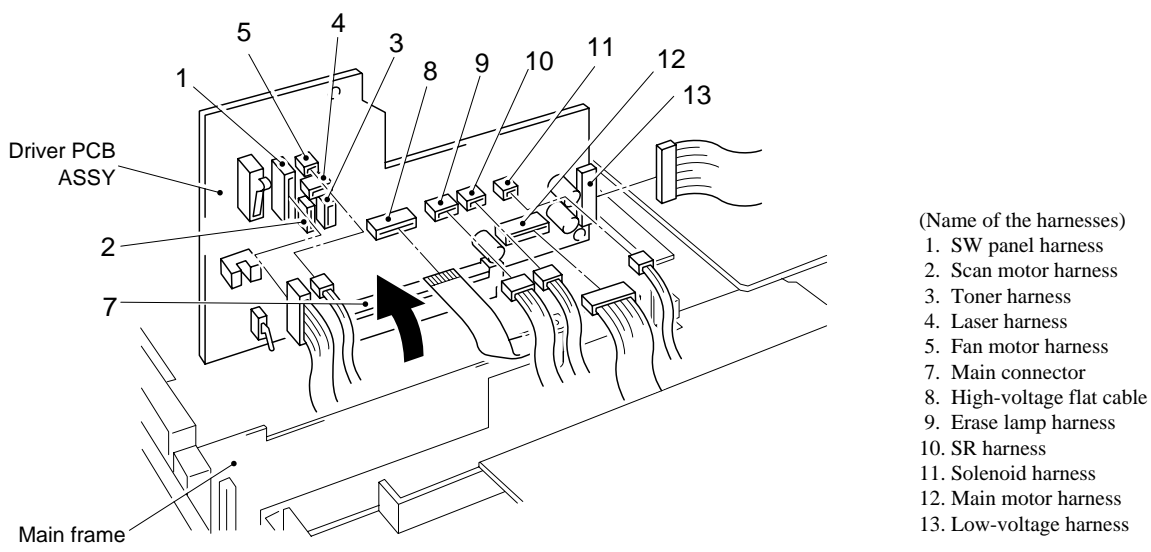

Fig. 3.28

- Note 1: When reassembling, the cable connectors must be inserted securely into the PCB connectors and the PCB must not be stressed by the harnesses.*
- Note 2: The connectors should be inserted by matching the housing color and the number of pins.*

3.13 Low-voltage Power Supply PCB ASSY

- (1) Remove the screw securing the low-voltage power supply PCB ASSY.
- (2) Disconnect the two connectors for the heater harness and the LV harness from the PCB.

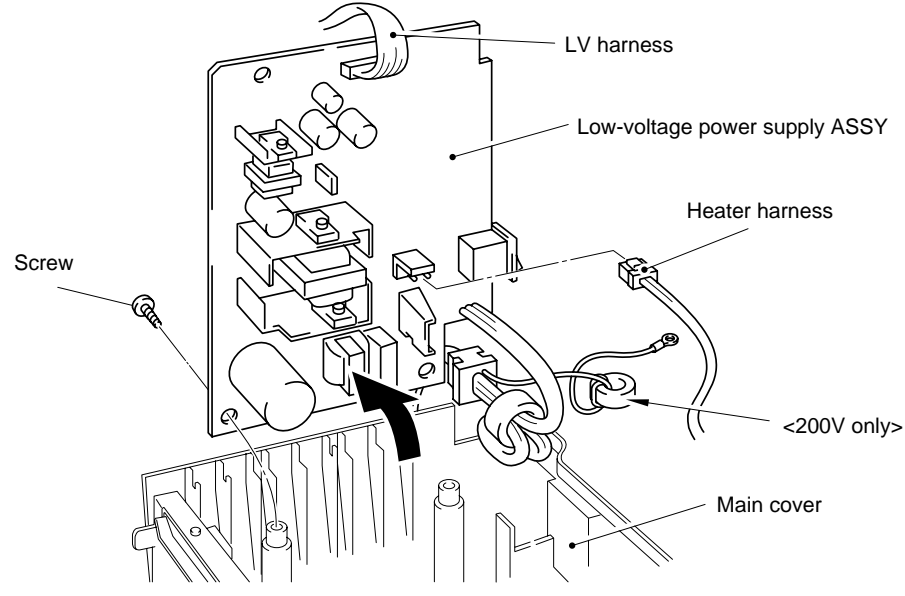

Fig. 3.29

3.14 High-voltage Power Supply PCB ASSY

- (1) Remove the screw securing the high-voltage power supply PCB ASSY.
- (2) Disconnect the HV flat cable from the PCB.

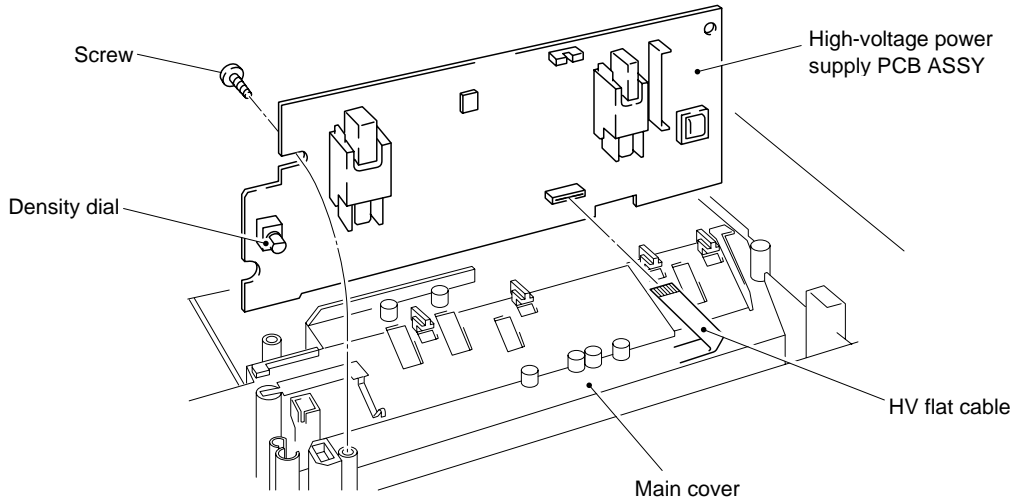

Fig. 3.30

Note: When reassembling, the flat side of the density dial shaft must be aligned with the flat side of the density dial plastic adjustment cover.

3.15 Fan Motor ASSY

- (1) Remove the screw securing the fan motor ASSY.
- (2) Release the two hooks of the fan holder from the main cover.

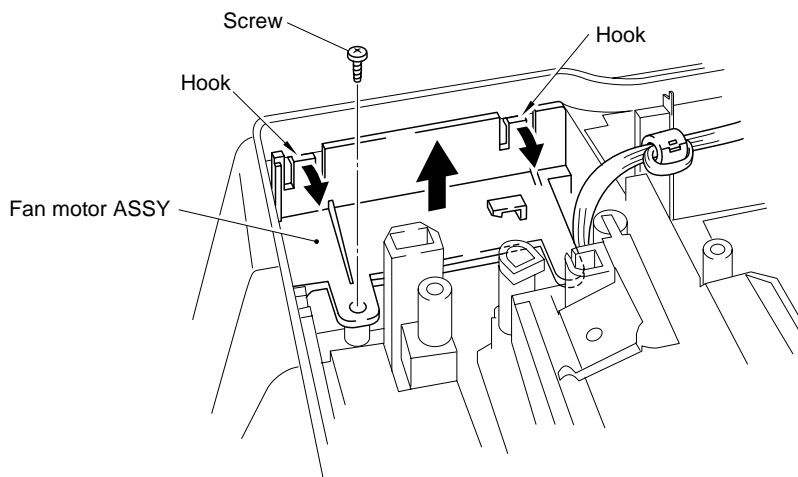

Fig. 3.31

- (3) Remove the two screws securing the fan motor.

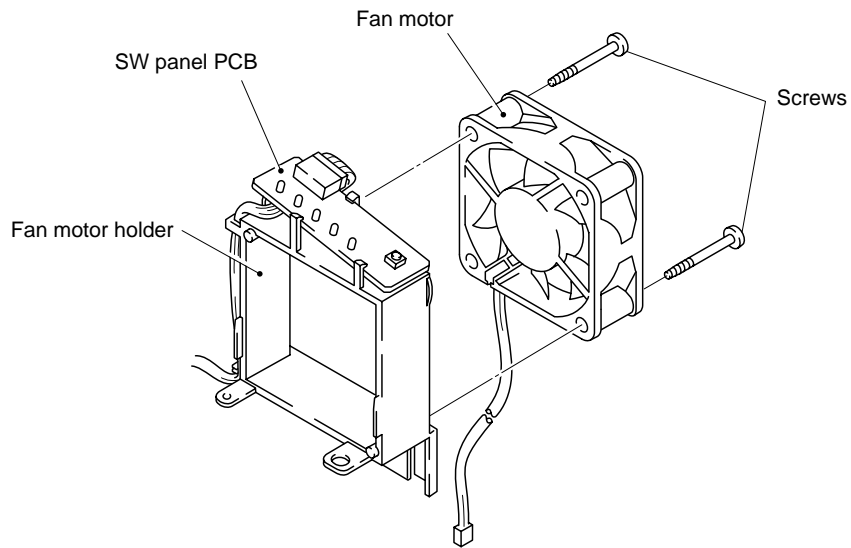

Fig. 3.32

3.16 Drive Unit

- (1) Unhook the heater harness from the drive unit.

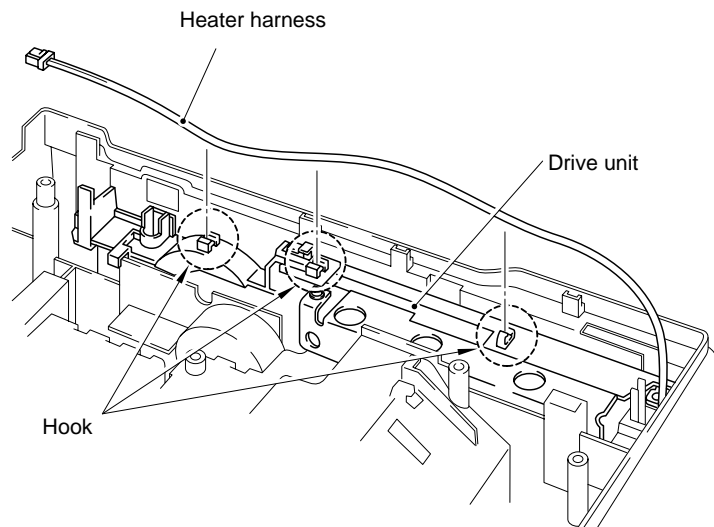

Fig. 3.33

- (2) Release the hook to remove the gear cover.
- (3) Remove the six screws securing the drive unit. Lift the drive unit while pressing and releasing the static removal plate spring on the drive unit.

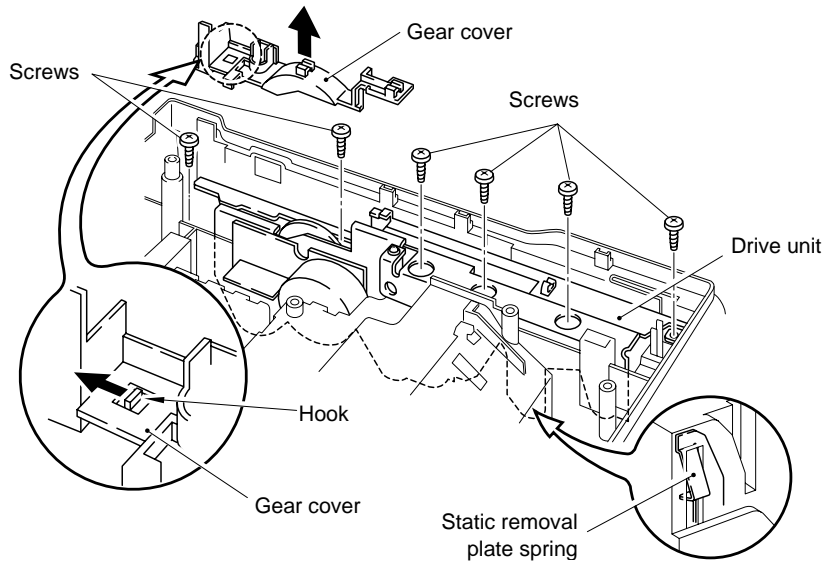

Fig. 3.34

3.17 Main Motor ASSY

- (1) Remove the four screws securing the main motor ASSY.

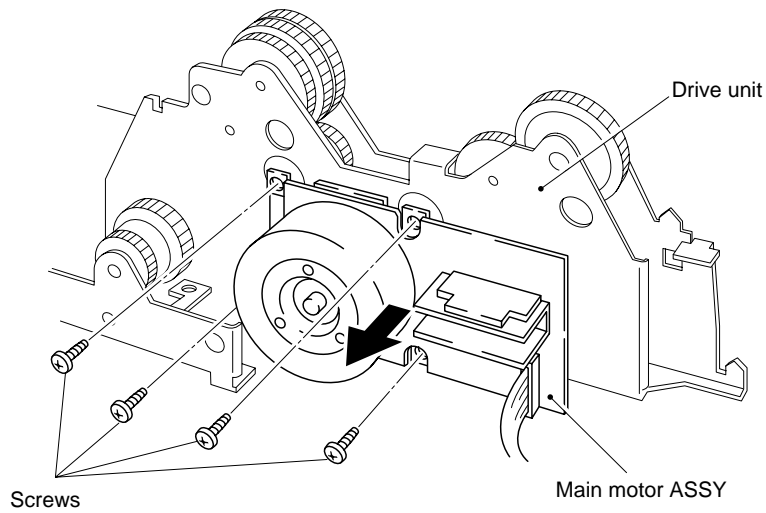

Fig. 3.35

3.18 Gears and Solenoid

- (1) Apply grease to the points shown below.

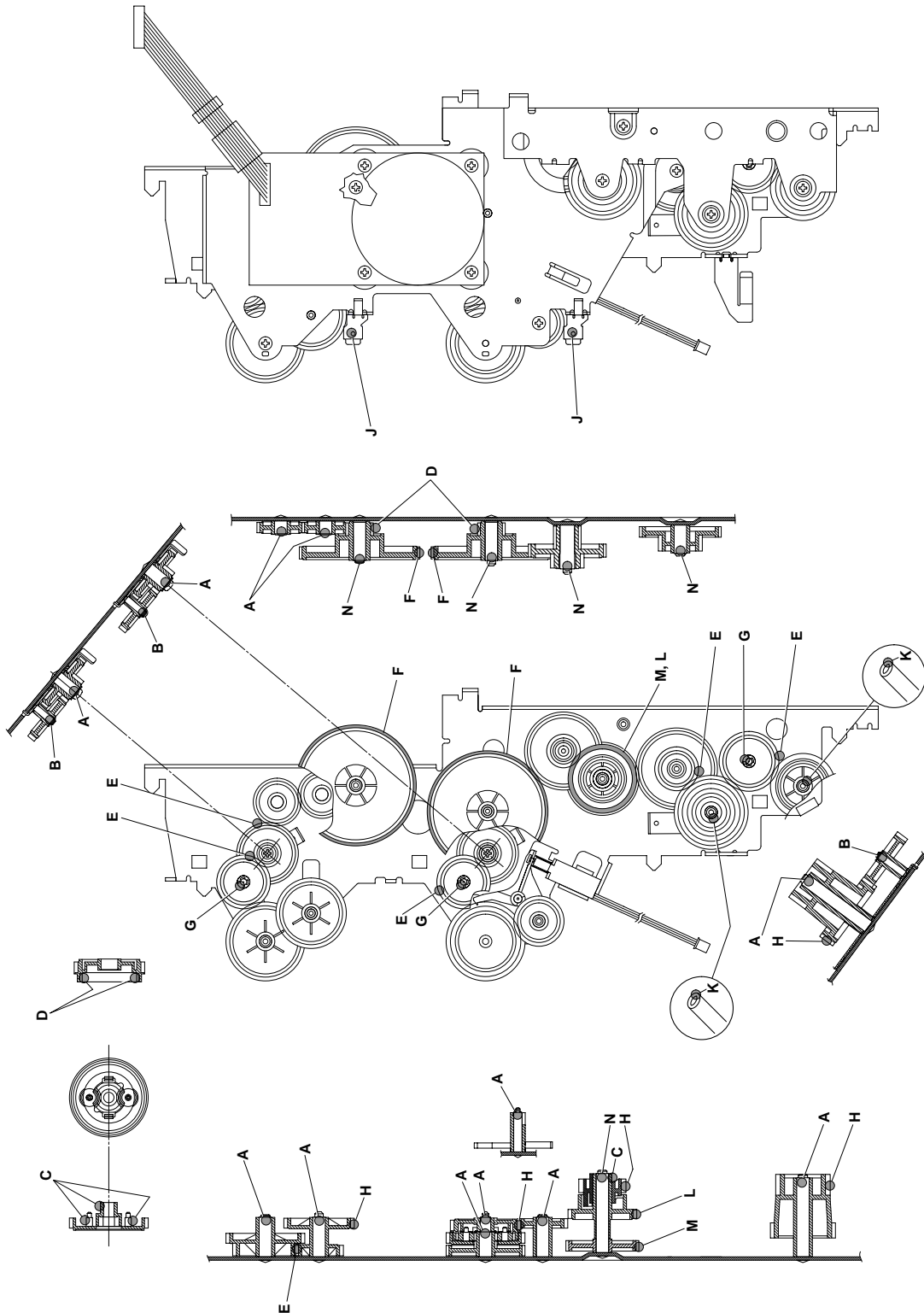

Fig. 3.36

Note: Follow instructions below when applying the grease.

Sign	When applying the grease	Grease	Application amount
A	Before installing the gear.	Dow Corning LTD. EM-30L	1 rice-grain size
B	After installing the bending washer, and before installing the gear.	Dow Corning LTD. EM-30L	1 rice-grain size
C	Before installing the gear.	Dow Corning LTD. EM-30L	1 rice-grain size
D		Dow Corning LTD. EM-30L	5 rice-grain size
E		Dow Corning LTD. EM-30L	5 rice-grain size
F		Dow Corning LTD. EM-D110	Refer to the Fig. 3.36
G		Dow Corning LTD. EM-30L	1 rice-grain size
H	After installing the drive unit on main body.	Dow Corning LTD. EM-30L	5 rice-grain size
J	After installing the drive unit on main body.	Kanto Kasei LTD. FLOIL GE334C or GE676	1/2 rice-grain size
K		Dow Corning LTD. EM-30L	1 rice-grain size
L		Dow Corning LTD. EM-D110	Refer to the Fig. 3.36
M		Dow Corning LTD. EM-D110	Refer to the Fig. 3.36
N	Before installing the gear.	Dow Corning LTD. EM-D110	5 rice-grain size

3.19 Paper Support

- (1) Pull the paper support down toward you and pull both legs outwards to release it.

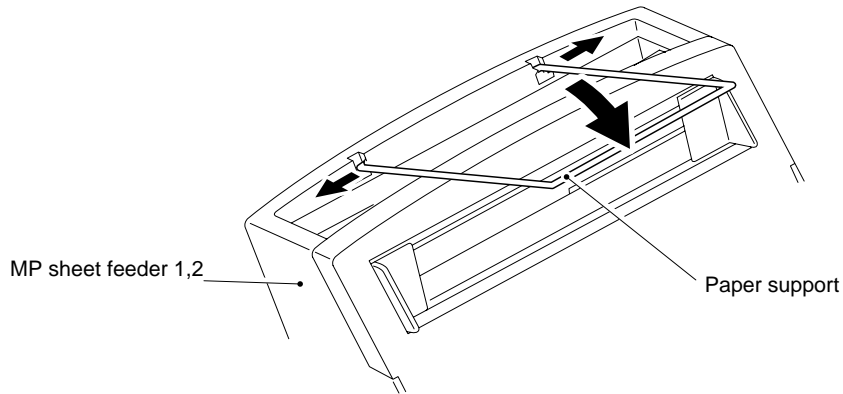

Fig. 3.37

3.20 Extension Support Wire

- (1) Raise the extension support wire toward you, press both legs inward to release it, and then release the paper stopper from the wire.

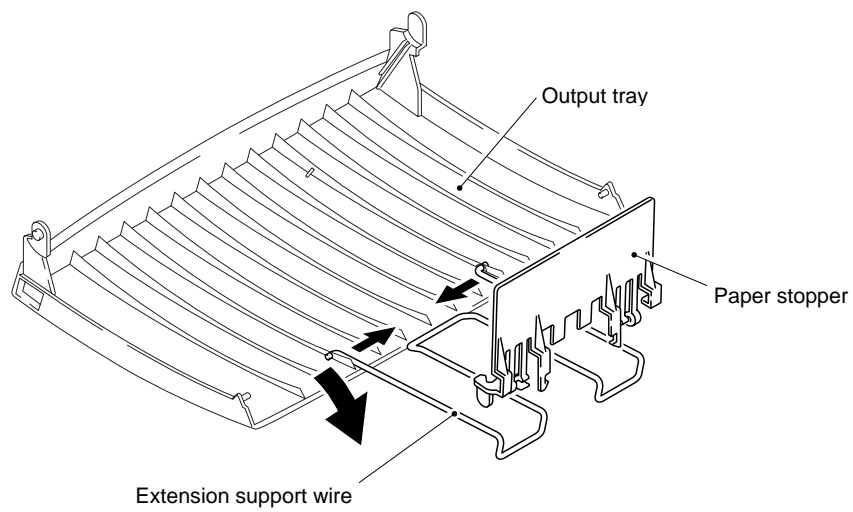

Fig. 3.38

4. PACKING

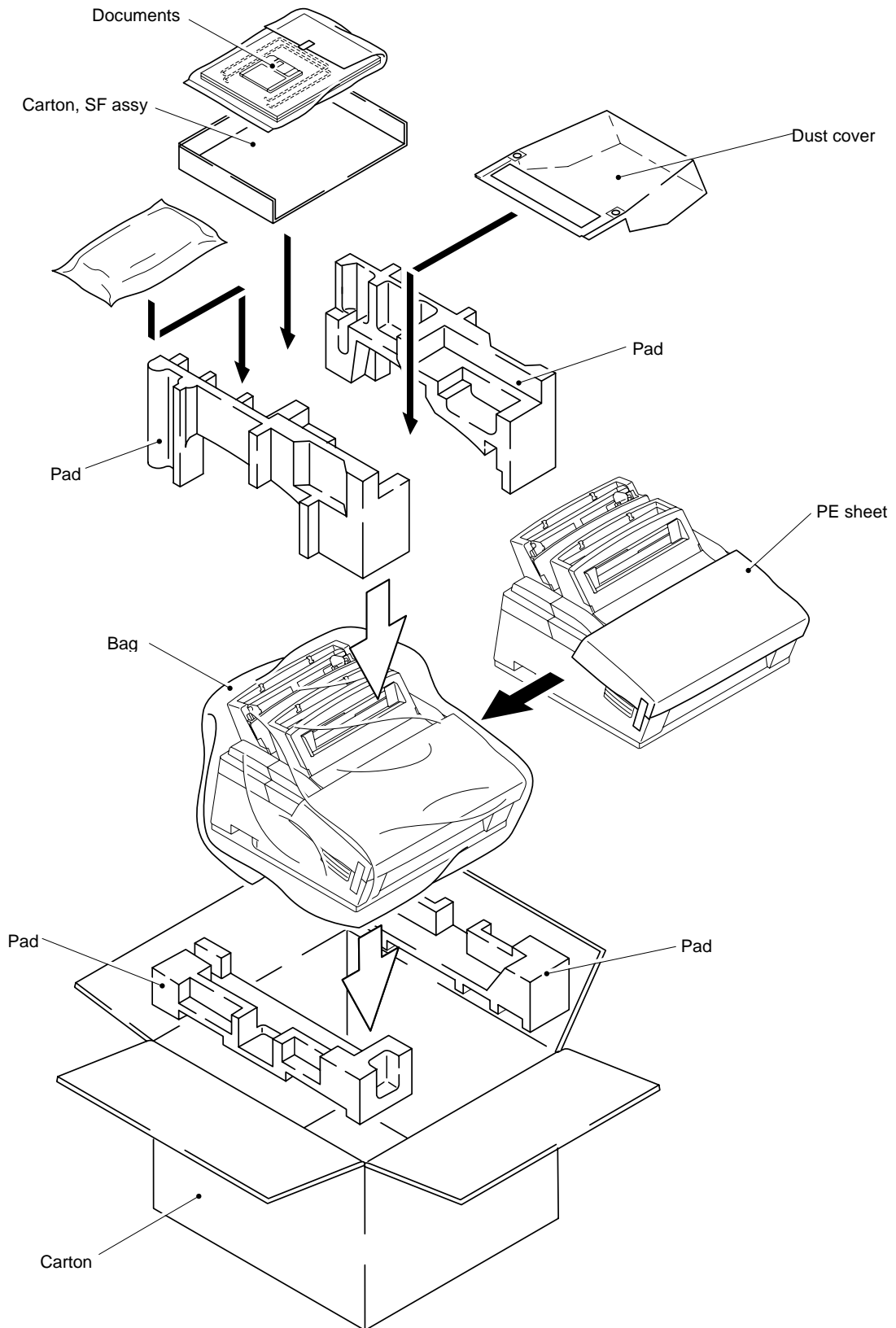

Fig. 3.39

CHAPTER IV MAINTENANCE AND TROUBLESHOOTING

1. INTRODUCTION

1.1 Initial Check

(1) Operating environment

Check if :

- The source voltage stays within $\pm 10\%$ from the rated voltage shown on the rating plate.
- The printer is installed on a solid, level surface.
- The room temperature is maintained between 10°C and 32.5°C. The relative humidity is maintained between 20% and 80%.
- The printer is not located in a dusty place.
- The printer is not exposed to ammonia fumes or other harmful gases.
- The printer is not located in a hot or humid area (such as near water or a humidifier).
- The printer is not exposed to direct sunlight.
- The room is well-ventilated.
- The printer is not placed where the ventilation hole of the printer is blocked.

(2) Print paper

Check if :

- A recommended type of print paper is being used (if the paper is too thick or too thin, or tends to curl, paper jams or paper feed problems may occur, or printed images may be blurred).
- The print paper is dampened. [If so, use fresh paper, and check whether the print quality improves or not.]

(3) Consumables

Check if :

- The Toner lamp is not lit on the control panel when a toner cartridge is installed in the printer. [If the above lamp is lit, replace the cartridge with a new one. If blank spots occur on printouts, take out the drum unit and slowly rock it to redistribute the toner evenly.]

(4) Others

Condensation:

When the printer is moved from a cold room into a warm room in cold weather, condensation may occur inside the printer, causing various problems as listed below:

- Condensation on the optical surfaces such as the scanning mirror, lenses, the reflection mirror and the protection glass may cause the print image to be light.
- If the photosensitive drum is cold, the electrical resistance of the photosensitive layer is increased, making it impossible to obtain the correct contrast when printing.
- Condensation on the corona unit may cause corona charge leakage.
- Condensation on the hopper gate and separation pad may cause paper feed troubles.

If condensation has occurred, wipe the effected units or parts with a dry cloth.

If the drum unit is unpacked soon after it is moved from a cold room to a warm room, condensation may occur inside the unit, which may cause incorrect images. Instruct the user to allow the unit to come to room temperature before unpacking it. This will take one or two hours.

1.2 Basic Procedure

If a malfunction or incorrect print appears, make an initial check following the basic procedure below:

- (1) Check the error lamps following the inspection procedure described later in this section. If no error lamps are lit, see Section 4 for troubleshooting information.
- (2) If any defective image output is found, follow the image defect fault descriptions in this section.

2. CONSUMABLE PARTS

2.1 Drum Unit

The Drum lamp is on when the drum unit is nearly at the end of its life.

Life expectancy: 20,000 pages at 20 pages per job
 8,000 pages at 1 page per job

Note: There are many factors that determine the actual drum life, such as temperature, humidity, type of paper and toner that you use, the number of pages per print job, etc..

2.2 Toner Cartridge

Toner low: The Data and Alarm lamps blink once every five seconds.

Toner empty: The Data and Alarm lamps blink once every second.

Life expectancy: 2,200 pages/a new toner cartridge
 (when printing A4- or letter-size paper at 5% print coverage)

Note: Toner life expectancy will vary depending on the type of average print job printed.

2.3 Periodical Replacement Parts

No.	Description	Part No.	Qty	service life (number of print)	Remarks
1	Fixing Unit Y (Cleaner ASSY HR)	UH3308001 (UH3310001)	1 1	(100,000)	120V
	Fixing Unit Y (Cleaner ASSY HR)	UH3309001 (UH3310001)	1 1	(100,000)	230V
2	Scanner Unit Y		1	(100,000)	
3	MP sheet feeder 1 ASSY Y (P pick-up roller shaft ASSY Y)		1	(100,000)	
			1		
4	MP sheet feeder 2 ASSY Y (P pick-up roller shaft ASSY Y)		1	(100,000)	
			1		

Note: The above table shows only estimated value, so these values are subject to change without prior notice.

3. IMAGE DEFECTS

3.1 Image Defect Examples

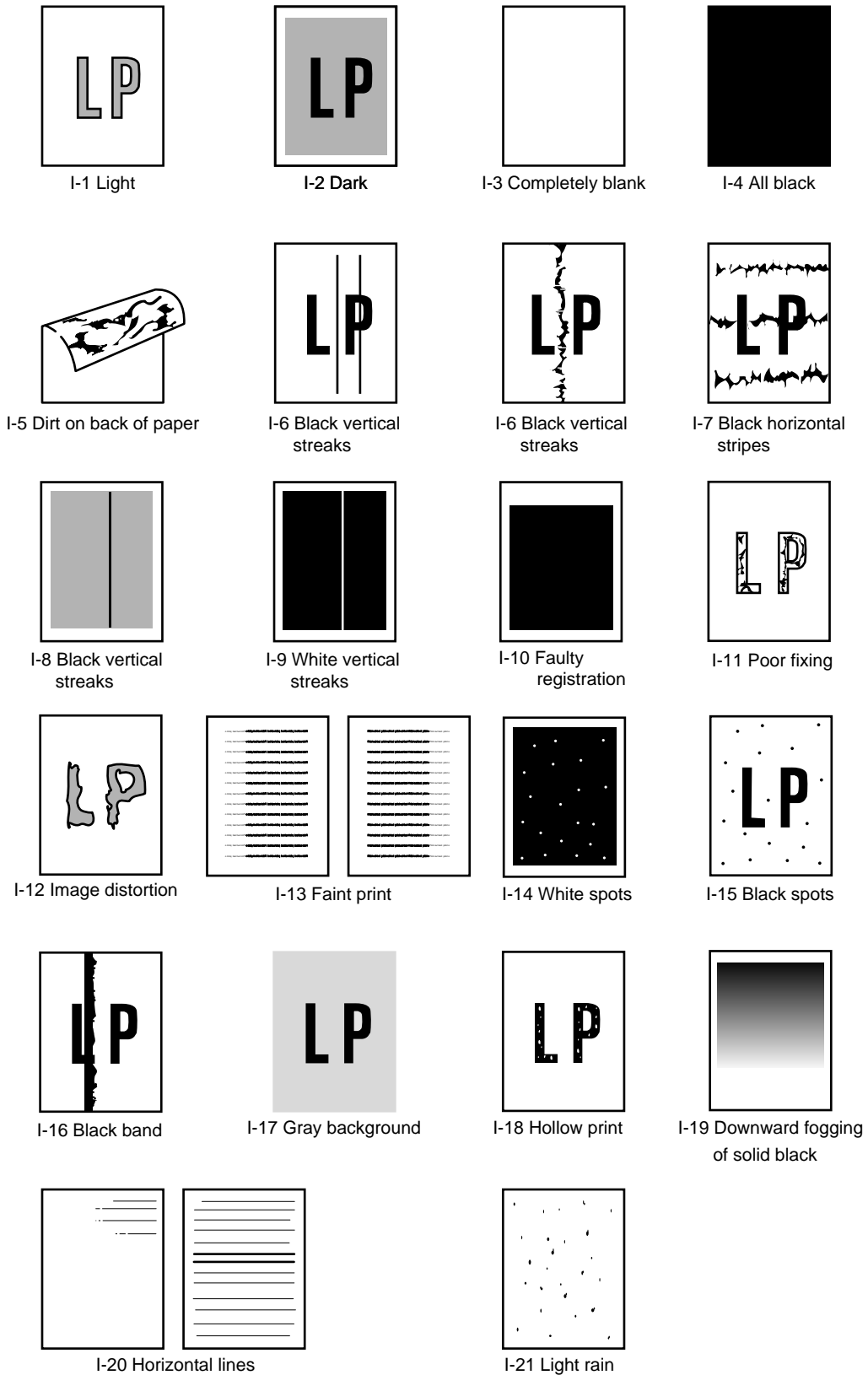
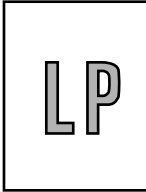

Fig. 4.1

3.2 Troubleshooting Image Defects

The following procedures should be followed in the event of specific image defects. See subsection 3.3 for information about the location of the high-voltage contacts and grounding contacts.

I-1	Light
-----	-------



Possible cause	Step	Check	Result	Remedy	HV.GND contacts (Fig.4-5)
Density dial	1	Is the density dial in the center of the click position?	No	Set it to the center detect position.	
Toner sensing failure (printer side)	2	Can printing be started with the drum unit removed?	Yes	Toner sensor failure. Check if the toner sensor needs cleaning and check the toner sensor connection.	
Toner sensing failure (toner cartridge side)	3	Is the problem solved when 4 or 5 pages are printed after the toner cartridge is replaced with a full one?	Yes	The wiper of the toner cartridge is defective. Replace the toner cartridge.	
Drum connection failure	4	Is all the contacts (HV, GND) connected with electrode when the drum unit is installed?	No	Clean contact electrodes both in the printer body and on the drum unit.	①
High-voltage power supply PCB failure	5	Check the harness connection between the high-voltage power supply PCB and the driver PCB.	No	If the connection is normal, replace the high-voltage power supply PCB.	
Driver PCB or main PCB failure	6	Perform the same check as step 5 above and also between the driver PCB and the main PCB.	No	Replace the driver PCB or the main PCB.	
Scanner unit failure	7	Is the problem solved by repealing the scanner unit?	Yes	Replace the scanner unit.	

I-2	Dark
-----	------



Possible cause	Step	Check	Result	Remedy	HV.GND contacts (Fig.4-5)
Density dial	1	Is the density dial at the center click position?	No	Set it to the center click position or reasonable position.	
Corona failure (soiled wire)	2	Is the corona wire dirty?	Yes	Clean the corona wire by using the wire cleaner.	⑧
Corona failure (contact failure)	3	Are the corona electrodes between the printer body and drum unit dirty?	No	Clean both electrodes.	⑥
Drum unit failure	4	Is the problem solved when the drum unit is replaced?	Yes	Replace the drum unit with a new one.	
H.V. power supply PCB	5	Are there any disconnected connectors?	No	Replace the H.V. power supply.	
Main PCB	6	Are there any disconnected connectors?	No	Replace the main PCB.	
Driver PCB	7	Are there any disconnected connectors?	No	Replace the driver PCB.	

I-3	Completely blank
-----	------------------

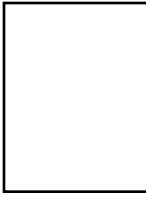

Possible cause	Step	Check	Result	Remedy	HV.GND contacts (Fig.4-5)
Developing bias contact failure	1	Are the developing bias contacts between the printer body and drum unit dirty?	Yes	Clean the electrodes at both sides.	⑦
Drum unit	2	Are the drum shaft and drum electrode of the printer body connected correctly?	Yes	Clean the shaft and the electrode.	①
			No	Check the connection between the shaft and the electrode.	①
Drum unit failure	3	Is the problem solved after the drum unit is replaced?	Yes	Replace the drum unit.	
Scanner harness connection failure	4	Is the scanner harness connected securely? Is there any play in the connection?	Yes	Reconnect the connector properly.	
Main/Driver PCB connection failure	5	Are printing signals being input to the scanner? Is the problem solved after the main PCB or the driver PCB replaced?	Yes	Replace the main PCB or the driver PCB.	
Scanner unit failure	6	Scanner interlock lever damaged. Scanner mirror is broken or loose.	Yes	Replace the scanner unit.	
			No	Replace the H.V. power supply.	

I-4	All black
-----	-----------



Possible cause	Step	Check	Result	Remedy	HV.GND contacts (Fig.4-5)
Corona failure	1	Is the corona wire of the drum unit broken?	Yes	Replace the drum unit.	
	2	Are the electric terminal springs in the printer body and the electrode on the bottom face of the drum unit dirty?	Yes	Clean the terminals in the printer and on the drum.	⑥
Harness connection	3	Is the scanner unit connected with the driver PCB correctly?	Yes	Check the harness connection between the scanner unit and the driver PCB.	
H.V. power supply PCB	4	Is the problem solved after H.V. power supply PCB replaced?	Yes	Replace the H.V. power supply PCB.	
Ditto	5	Perform the same check as in step 3.	No	Replace the panel sensor PCB.	
Main PCB	6	Is the problem solved after main PCB replaced?	Yes	Replace the main PCB.	
Driver PCB	7	Is the problem solved after driver PCB replaced?	Yes	Replace the driver PCB.	

I-5	Dirt on the back of paper
-----	---------------------------

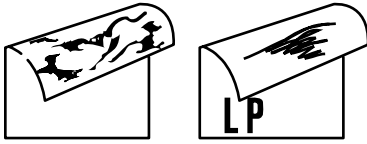

Possible cause	Step	Check	Result	Remedy
Fixing unit	1	Is the pressure roller dirty? Is any other area in the printer dirty?	Yes	Clean the pressure roller. (See the following note.)
Dirt in the drum unit	2	Is the transfer roller dirty? is the problem solved after the drum unit replaced?	Yes	Replace the drum unit
			No	Replace the H.V. power supply PCB.

Note: Cleaning of the pressure roller

- (1) Set three or more sheets of paper in MP sheet feeder 1 (or 2).
- (2) Open the top cover.
- (3) Turn on the power switch while holding down the switch on the control panel.
- (4) Release the panel switch when the Drum lamp is on.
- (5) Close the top cover.
- (6) Hold down the panel switch until the Ready lamp is on, and then release the switch.
- (7) Print three patterns; grid, zip and solid black.
- (8) Turn off the power switch with the top cover closed.
- (9) Set paper in the manual slot with the solid black side up.
- (10) Turn on the power switch while holding down the switch on the control panel.
- (11) Release the panel switch when the Drum lamp is on.
- (12) Press the panel switch again and release it immediately.
- (13) Print a page of test pattern while cleaning the pressure roller.

I-6	Black vertical streaks	Black and blurred vertical streaks
-----	------------------------	------------------------------------

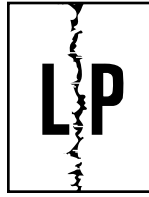
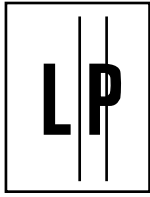

Possible cause	Step	Check	Result	Remedy	HV.GND contacts (Fig.4-5)
Corona failure	1	Is the corona wire dirty?	Yes	Clean the corona wire with the wire cleaner.	⑧
Corona failure	2	Is the vertical block streak about 10mm wide? Is the corona wire cleaner not in its home position?	Yes	Return the wire cleaner to its home position.	
Dirt in the paper feed system	3	Is the paper tray or feed system on the drum unit soiled with toner?	Yes	Clean the toner off.	
Scratch on the drum	4	Is the drum surface scratched?	Yes	Replace the drum unit.	
Cleaning failure	5	Is the drum surface dirty with toner in streaks?	Yes	Replace the drum unit.	
Scratch on the heat roller	6	Is the surface of the heat roller scratched?	Yes	Replace the fixing unit.	

Note: Is you print the same pattern continuously, the drum will be worn away and black vertical streaks appear on the paper.

I-7	Black and blurred horizontal stripes
-----	--------------------------------------



Possible cause	Step	Check	Result	Remedy
Scratch on the drum	1	Are the horizontal stripes at 94mm (OPC drum) intervals?	Yes	Replace the drum unit.
Toner stuck on the developer roller	2	Are the horizontal stripes at 25mm (developer roller) intervals?	Yes	Print several sheet and see what happens. The problem will disappear after a while. If not, replace the drum unit.
Scratch on the fixing roller	3	Are the horizontal streaks at 63mm (heat roller) intervals?	Yes	Replace the fixing unit.
SR PCB	4	Is the problem solved after the SR PCB replaced?	Yes	Replace the SR PCB.

I-8	Black vertical streaks (in the gray background)
-----	---

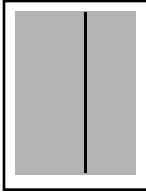

Possible cause	Step	Check	Result	Remedy
Translucent stain on the scanner window	1	Are there any stains?	Yes	Clean the scanner window. If it is not effective, replace the scanner unit.

I-9	White vertical streaks
-----	------------------------

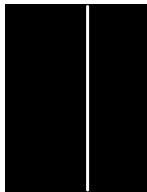

Possible cause	Step	Check	Result	Remedy
Scanner window dirty	1	Is the scanner window dirty?	Yes	Clean the scanner window with a dry tissue.
Transfer failure	2	Is the transfer roller scratched?	Yes	Replace the drum unit.

I-10	Faulty registration
------	---------------------

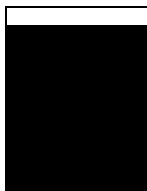

Possible cause	Step	Check	Result	Remedy
Excessive paper load	1	Is the paper loaded in the paper feeder more than 22mm deep?	Yes	Instruct the user to keep paper loads below 22mm in depth.
Print paper	2	Is the specified weight of the recommended paper being used?	No	Instruct the user to use the recommended types of paper.
Ditto	3	Is the first printing position within ± 1 mm of the tolerance specification?	Yes	Adjust the Y offset by using the utility software supplied.
Paper resist sensor position incorrect	4	Is the position of the paper resist sensor normal?	No	Reposition the sensor to the correct position.

I-11	Poor fixing
------	-------------

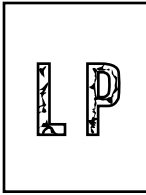

Possible cause	Step	Check	Result	Remedy
Printing paper	1	Is thick paper more than 36lb weight in use?	Yes	Instruct the user to use paper of the recommended weight and thickness.
Toner sensing failure	2	Is the problem solved by replacing the drum unit or the toner cartridge? (When printing is faint.)	Yes	Toner is empty. The toner sensing is defective, clean the toner sensor. If the wiper in the toner cartridge is broken, replace the toner cartridge with a new one.
Thermistor failure	3	Is the thermistor fitted correctly?	No	Fit the thermistor correctly.
Low-voltage power supply PCB failure	4	Is the problem solved by replacing the low-voltage power supply PCB?	Yes	Replace the low-voltage power supply PCB.

I-12	Image distortion
------	------------------

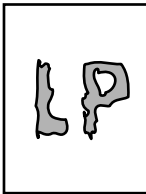

Possible cause	Step	Check	Result	Remedy
Scanner	1	Is the scanner unit secured to the frame incorrectly? Is there any play?	Yes	Secure the unit correctly and tighten the screws.
Scanner LD emission failure Scanner motor rotation failure	2	Is the laser diode or the laser scanner motor defective?	Yes	Replace the scanner unit.
Scanner connection failure	3	Is the scanner harness connected properly? Is it coming loose?	Yes	Connect the harness correctly.

I-13	Faint print
------	-------------

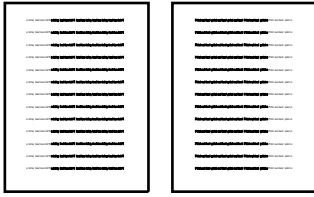

Possible cause	Step	Check	Result	Remedy
Printer not level	1	Is the printer placed horizontally?	No	Place the printer on a flat surface.
Drum unit	2	Does the problem happened immediately after replacing the drum unit with a new one?	Yes	Remove and shake the drum unit horizontally with care.
Scanner window dirty	3	Is the window of the laser scanner dirty?	Yes	Clean the scanner window with a dry tissue.
Scanner unit failure	4	Is the problem solved by replacing the scanner unit?	Yes	Replace the scanner unit.

I-14	White spots
------	-------------

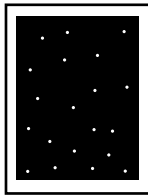

Possible cause	Step	Check	Result	Remedy
Toner cartridge	1	Is the toner in the toner cartridge almost empty?	Yes	Shake the drum unit horizontally. Replace the toner cartridge with a new one.
			No	Replace the drum unit.
Print paper	2	Is the problem solved after change to specified of fresh unpacked paper?	Yes	Recommend the user to change the paper. (Damp (wet) paper might be used.)
Environment	3	Check if the problem still appears after the printer has warmed up.	Yes	Replace the drum unit. Advise the user of the specified print environment.

I-15	Black spots
------	-------------



Possible cause	Step	Check	Result	Remedy
Drum unit	1	Are the spots at 94mm intervals? The problem is not solved after printing a few pages.	Yes	If toner remains stuck, wipe it off gently with a cotton swab. Replace the drum unit if the OPC drum is scratched or deteriorated (exposed). (Refer to the following note.)
Fixing unit	2	Are the spots at 63mm intervals? And the problem is not solved after printing a few pages.	Yes	Check and clean the heat roller with a cloth dampened with alcohol. Replace the fixing unit.
SR PCB	3	Is the problem solved after the SR PCB replaced?	Yes	Replace the SR PCB.

Note: Clean the drum unit as follows:

- (1) Place the printing samples in front of the process unit, and find the exact portion of image defect.

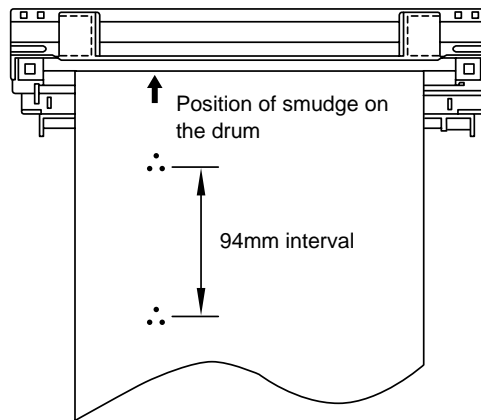

Fig. 4.2

- (2) Turn the drum gear by finger while looking at the surface of the OPC drum.

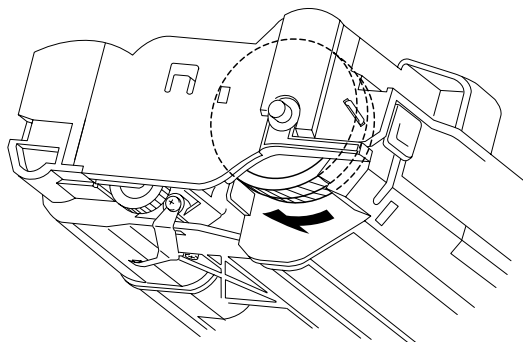

Fig. 4.3

- (3) Wipe the surface of the photosensitive drum with a cotton swab until the dust or paper powder on the surface toner lamp comes off.

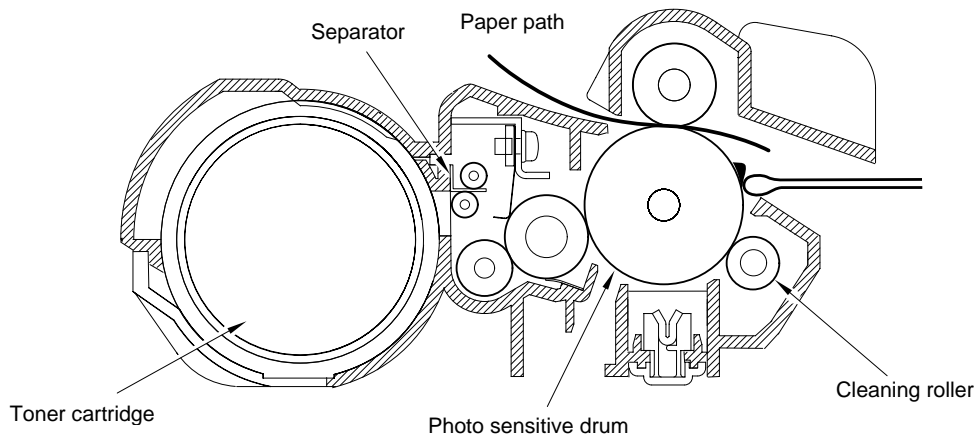
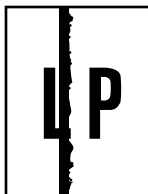

Fig. 4.4

Caution: Don't wipe the surface of the photosensitive drum with something sharp. (ball-point pen etc.)

Use the cleaning liquid which is mixed ethyl alcohol and pure water at the rate of each 50%.

I-16	Black bank
------	------------



Possible cause	Step	Check	Result	Remedy
Drum unit	1	Is the wire cleaner positioned at its home position?	No	Return the wire cleaner to its home position.
			Yes	Replace the drum unit.

I-17	Gray background
------	-----------------



Possible cause	Step	Check	Result	Remedy
Density dial	1	Is the problem corrected by adjusting the density dial?	Yes	Adjust the dial to the most suitable position.
Print paper	2	Does the paper being used meet the paper specification (weight, etc.).	No	Recommend to change the paper to a specified type of the paper.
			Yes	Recommend to change the paper to a fresh pack paper.
Drum unit	3	Is the problem solved after replacing the drum unit?	Yes	Replace the H.V. power supply.
				Replace the drum unit.

Note: The following cases raise the possibility of this problem.

1. The drum unit is at the end of its life.
2. There is dust or paper powder.
3. A large number of paper whose width is narrower than A4 is printed.

I-18	Hollow print
------	--------------



Possible cause	Step	Check	Result	Remedy
Print paper	1	Is thick paper of more than 42lb being used or extremely rough surface paper?	Yes	Recommend to use the specified type of paper.
			No	Refer and compare with I-14.

I-19	Downward fogging of solid black
------	---------------------------------



Possible cause	Step	Check	Result	Remedy
Drum unit	1	Is the problem solved after replacing the drum unit?	Yes	Replace the drum unit.
SR PCB	2	Is the problem solved after replacing the SR PCB?	Yes	Replace the SR PCB.

I-20	Horizontal lines
------	------------------

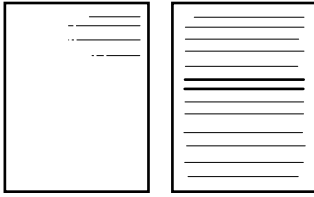

Possible cause	Step	Check	Result	Remedy	HV.GND contacts (Fig.4-5)
SR electrode	1	Are the SR electrodes between the printer body and the drum unit dirty?	Yes	Clean both electrodes.	⑨
SR connection failure	2	Are the SR electrodes between the printer body and the drum unit connected correctly?	No	Check the SR connection.	
Feed roller	3	Are the feed roller shaft and the ground contact connected correctly?	No	Check the connection between the shaft and the ground contact.	⑩

I-21	Light rain
------	------------



Note: Make the printer in the light rain test mode as follows before checking;

1. Turn on the power switch and open the top cover.
2. Hold down the panel switch until all the lamps are on, and then release the switch.

Possible cause	Step	Check	Result	Remedy
Drum unit failure	1	Is the problem solved after replacing the drum unit which contains no more starter sheet**?	Yes	Replace the drum unit.
SR PCB failure	2	Is the problem solved after replacing the SR PCB?	Yes	Replace the SR PCB.
High-voltage power supply PCB failure	3	Is the problem solved after replacing the High-voltage power supply PCB?	Yes	Replace the High-voltage power supply PCB.

***Note: Make sure to use the used drum unit which has already ejected the starter sheet. It is not possible to find the drum unit failure if you use a new drum unit with the starter sheet.*

3.3 Location of High-voltage Contacts and Grounding Contacts

Grounding contacts

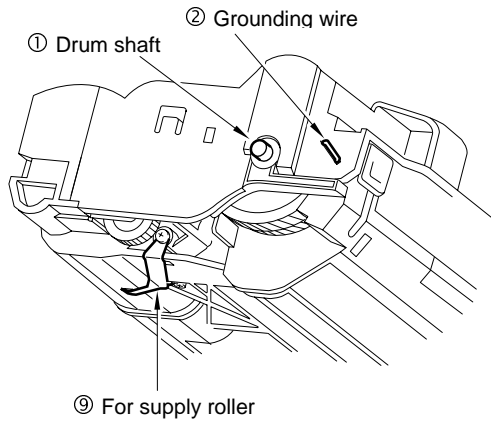

High-voltage contacts

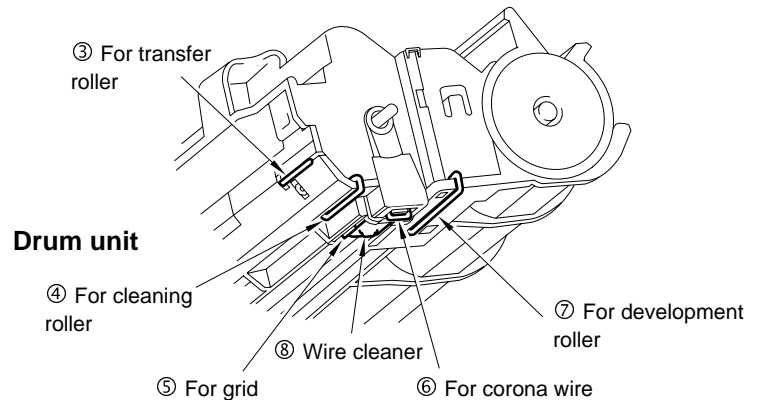

Fig. 4.5

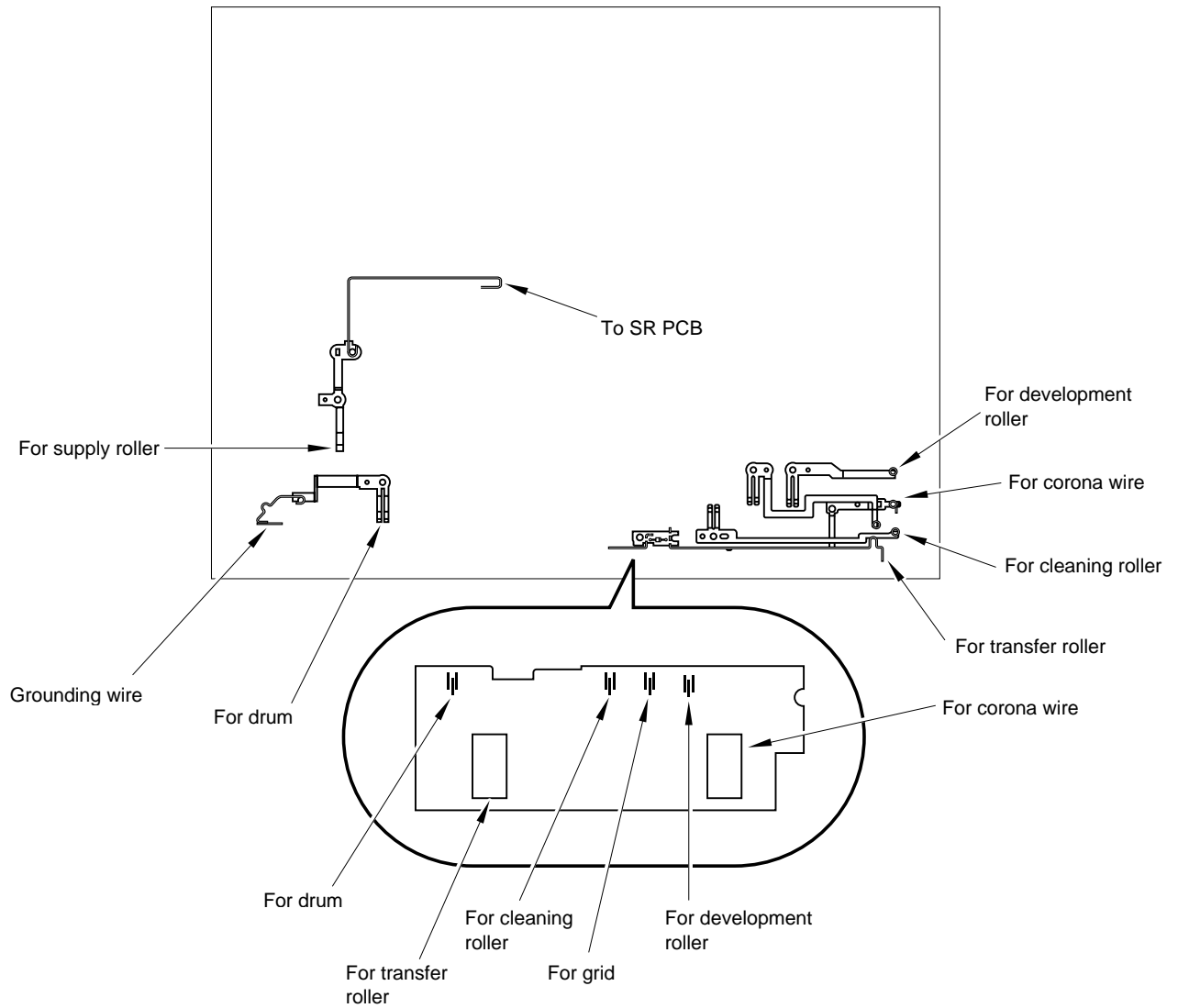

Fig. 4.6

3.4 Location of Feed Roller Shaft and Grounding Contacts

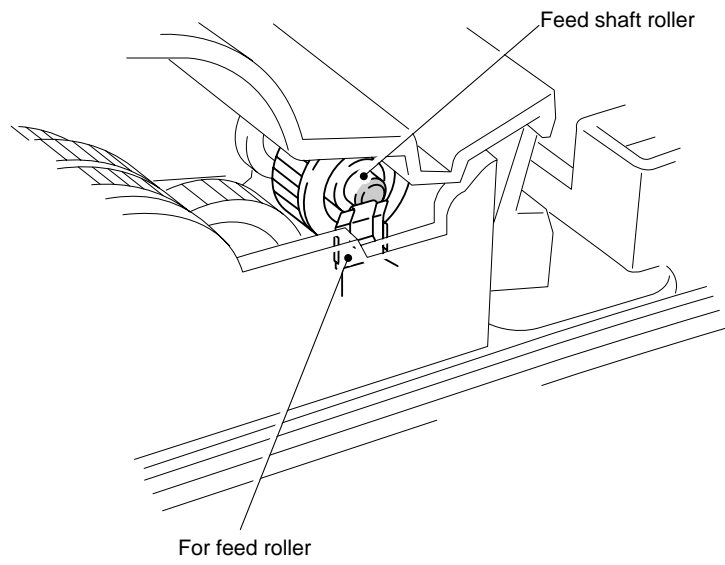

Fig. 4.7

4. PAPER JAM

Problem	Type of jam	Cause	Temp measure
Jam at power on	Paper stuck	The paper feed sensor of paper eject sensor is turned on.	Remove the paper inside the printer. If there is no paper exist, check suspected sensors referring to note and clear the problem.
Top of paper stopped at 20mm from the fixing unit. The paper feed roller rotated twice.	No paper	The paper feed sensor is not turned on.	Check the paper feed sensor motion referring to note and clear the problem.
Top of paper stopped at 250mm from the fixing unit. Next paper is not fed.	1) Jam caused by paper length considered longer than 400mm (16 inches).	1) The paper feed sensor is not returned properly, and is not turned off.	1) Check the paper feed sensor motion referring to note and clear the problem.
	2) Jam caused by malfunction of the regist sensor	2) The regist sensor actuator is not returned to the home position.	2) Attach the film onto the regist sensor actuator.
Top paper stopped at the transfer roller.	Jam caused by paper length considered shorter than 80mm.	The paper feed sensor was turned off earlier.	Malfunction of actuator or hardware noise. Check sensors referring to note and clear the cause of the problem.
Paper was fed approx. 20mm transfer roller.	Jam caused by delay of paper feed.	Due to the paper dust or rubber of the paper feed roller war, paper was not fed in proper timing.	Remove the paper dust attached to the paper feed roller. If the rubber is worn out, replace it with new one.
Top of paper stopped at 17mm from the contact point of the heat roller and pressure roller.	Jam caused paper is not ejected from paper eject sensor.	Paper eject sensor does not work properly and is not turned off. (single printing)	Check the sensor motion referring to note and clear the problem.
Top of paper stopped at 35mm from the contact point of the heat roller and pressure roller.	Jam caused paper is not ejected from paper eject sensor.	Paper feed sensor is not turned on.	Check the sensor motion referring to note and clear the problem.
Jam occurred after ejecting paper.	Same as above.	Same as above. (continuous printing)	Same as above.
Top of paper stopped at 20mm from the fixing unit.	1) Cover open.	1) Cover is not closed properly.	1) Check if the drum unit is installed correctly.
	2) Bug	2) Bug	2) Please inform BIL.

Note: How to make the sensors

- (1) Open the cover.
- (2) Power on the printer while pressing the panel switch.
- (3) Release the panel switch.
- (4) Press and release the panel switch.

Results:

*Alarm Lamp is ON = Paper feed sensor is turned ON

*Drum Lamp is ON = Paper eject sensor is turned ON

5. TROUBLESHOOTING MALFUNCTIONS

When carrying out countermeasures for malfunctions as described in this section, check connectors for contact failure before measuring the voltage at the specified connector pins.

M-1	No AC power supplied
-----	----------------------

Possible cause	Step	Check	Result	Remedy
Supply voltage	1	Is the correct voltage present at the outlet?	No	Inform the user that the correct voltage is not supplied at the outlet.
Power plug	2	Is the power cord securely plugged into the outlet?	No	Plug the power cord securely into the outlet.
Fuse (F1, F2)	3	is the fuse blown?	Yes	If the fuse blows again immediately after replacing the low-voltage power supply PCB, check that there is not a short circuit somewhere in the AC power supply line.
Wiring	4	Unplug the power supply plug. Is there a broken wire between the AC input connector of the low-voltage power supply and the power plug?	Yes	Replace the AC power cord.

M-2	No DC power supplied
-----	----------------------

Possible cause	Step	Check	Result	Remedy												
AC power supply	1	Is AC power supplied between connectors CN1-L and CN1-N when the power plug is plugged into the outlet?	No	Follow the same check procedure of M-1 "No AC power supplied".												
Wiring, DC load	2	Turn the power switch OFF and disconnect the P13 connector (Driver PCB). Turn the power switch ON again. Measure the voltages between the terminals. Do the measured voltage satisfy the prescribed value in the table below?	Yes	Turn the power switch OFF, reconnect the connector and turn the power switch ON again. If the protector circuit is activated, check the connector, the wiring from the connector, and the DC load.												
Low-voltage power supply PCB			No	Replace the low-voltage power supply PCB.												
		<table border="1"> <thead> <tr> <th>PCB</th> <th>+ lead pin</th> <th>- lead pin</th> <th>Voltage</th> </tr> </thead> <tbody> <tr> <td>Driver</td> <td>P13-4.5</td> <td>P13-2.3</td> <td>Approx. 24V</td> </tr> <tr> <td></td> <td>P13-8.9</td> <td>P13-6.7</td> <td>Approx. 5V</td> </tr> </tbody> </table>	PCB	+ lead pin	- lead pin	Voltage	Driver	P13-4.5	P13-2.3	Approx. 24V		P13-8.9	P13-6.7	Approx. 5V		
PCB	+ lead pin	- lead pin	Voltage													
Driver	P13-4.5	P13-2.3	Approx. 24V													
	P13-8.9	P13-6.7	Approx. 5V													

Caution: If you analyze malfunctions with the power plug inserted into the power outlet, special caution should be exercised even if the power switch is OFF because it is a single pole switch.

M-3	Main motor unrotated
-----	----------------------

Possible cause	Step	Check	Result	Remedy				
Failure of connector	1	Is the connection of connector P12 on the driver PCB correct?	No	Reconnect the connector.				
Main motor (M1)	2	Disconnect connector P12 from the driver PCB. Measure the resistance between the connector pins of the main motor by using a circuit tester. Do the measured resistances satisfy the prescribed values in the table below? <table border="1" data-bbox="555 701 914 790"> <tr> <td>P12-1 and P12-3</td> <td>Approx. 9Ω</td> </tr> <tr> <td>P12-4 and P12-6</td> <td>Approx. 9Ω</td> </tr> </table>	P12-1 and P12-3	Approx. 9Ω	P12-4 and P12-6	Approx. 9Ω	No	Replace the Main motor.
P12-1 and P12-3	Approx. 9Ω							
P12-4 and P12-6	Approx. 9Ω							
Driver PCB	3	is the problem solved by replacing the driver PCB?	Yes	Replace the driver PCB.				

M-4	No paper supplied
-----	-------------------

Possible cause	Step	Check	Result	Remedy
Connection failure	1	Is the contact of connector P11 on the driver PCB good?	No	Reconnect the connector.
Driver PCB circuit	2	Set paper on the manual paper slot and make the test print by pressing the switch on the control panel.	No	Replace the driver PCB.
Paper pick-up clutch solenoid		Does the voltage between pins 2 (SOLENOID) and 1 (24V) of the P11 connector on the driver PCB change from approx. 24V DC to 0V within the specified time?	Yes	Replace the paper pick-up solenoid.
MP tray unit failure	3	Is the surface of the separation pad or the pick up roller worn out or stained?	Yes	Clean the surface or replace.
Main PCB	4	Is the problem solved by replacing the main PCB?	Yes	Replace the main PCB.
Relay PCB	5	Is the problem solved by replacing the relay PCB?	Yes	Replace the relay PCB.

M-5	Insufficient output from high-voltage power supply unit
-----	---

Possible cause	Step	Check	Result	Remedy
High-voltage contact	1	Do any of the terminals on the high-voltage contacts have dirt or contact burns?	Yes	Clean the high-voltage contact.
	2	Check the connection of the harness between the high-voltage power supply and the driver PCB is OK.	Yes	Replace the high-voltage power supply PCB.
			No	Reconnect the harness between the high-voltage power supply and the driver PCB.

M-6	SR PCB failure
-----	----------------

Possible cause	Step	Check	Result	Remedy
SR bias contact	1	Do any of the terminals on the SR contacts have dirt or contact burns?	Yes	Clean the SR bias contact.
Ditto	2	Check the connection of the harness between the SR PCB and the driver PCB.	Yes	Replace the SR PCB.

M-7	Fixing heater temperature failure
-----	-----------------------------------

Possible cause	Step	Check	Result	Remedy
Poor thermistor harness contact	1	Are the connectors on the erase lamp PCB and the high-voltage power supply PCB secured correctly?	No	Connect the connectors securely.
Blown thermal fuse	2	Remove the fixing unit and measure the resistance between the input connectors. Is it open circuit?	Yes	Replace the fixing unit.
Thermistor failure	3	Is the thermistor installed properly?	Yes	Replace the fixing unit.
			No	Reinstall the thermistor properly.
Halogen heater lamp failure	4	Remove the fixing unit and measure the resistance of the fixing unit lamp. Is it open circuit?	Yes	Replace the halogen heater lamp.

M-8	BD failure
-----	------------

Possible cause	Step	Check	Result	Remedy
Harness connection failure	1	Is connector P4 on the driver PCB secured correctly?	No	Connect it securely.

M-9	Scanner failure
-----	-----------------

Possible cause	Step	Check	Result	Remedy
Harness connection failure	1	Is the connection of the scanner motor connector P2 on the driver PCB secured?	No	Reconnect the connectors securely.
Power supply input	2	Is the voltage between pins 1 (+24VDC) and 2 (GND) of connector P2 on the driver PCB 24 Volts DC?	No	Check if +24VDC is supplied between pins 4.5 (+24VDC) and 2.3 (+24VRET) of connector P13 on the driver PCB. If not, check the power supply output on the low-voltage power supply PCB.
			Yes	Replace the scanner unit.

F-1	Double feeding
-----	----------------

Possible cause	Step	Check	Result	Remedy
Paper	1	Is paper of a recommended type being used?	No	Instruct the user to use recommended types of paper.
Separation pad	2	Is the surface of the separation pad worn out?	Yes	Replace the MP sheet feeder.

F-2	Wrinkles
-----	----------

Possible cause	Step	Check	Result	Remedy
Paper	1	Is paper of a recommended type being used?	No	Instruct the user to use the recommended types of paper.
	2	Is the wrinkle problem solved if new paper is used?	Yes	Instruct the user how to store paper so that it does not absorb moisture.
Fixing unit entrance guide	3	Is the entrance guide dirty?	Yes	Clean the entrance guide.
Fixing unit	4	Is the pressure roller dirty?	Yes	Clean the pressure roller
			No	Replace the fixing unit.

6. INSPECTION MODE

6.1 Incorporated Inspection Modes

The printer incorporates various inspection modes such as the factory inspection mode and the test print mode. The inspection mode varies depending on the model of the printer.

This printer supports a factory inspection mode, continuous grid pattern print mode, 3 patterns print mode and NV-RAM value dump mode.

The operation of the inspection mode is as follows.

- (1) Turn off the power switch of the printer.
- (2) With the top cover open, turn on the power switch while holding down the switch on the control panel.

When you enter this inspection mode, the Drum lamp is ON. Holding down the panel switch will cause the lamps turn ON in the order Drum → Alarm → Ready → Data → Drum. When you release the switch, a mode is selected.

The mode selected is indicated by the lamp which is ON when you release the switch.

The inspection modes are assigned to the respective lamps as shown below.

Lamp	Type of inspection
Drum	Factory inspection mode
Alarm	Continuous grid pattern print mode
Ready	3 patterns print mode (grid → zip → black)
Data	NV-RAM value dump mode
Drum + Alarm	ROM code reprogramming mode (only when the flash memory is fitted)
Alarm + Ready	RAM check
Ready + Data	4% density pattern print mode

Details of the factory inspection mode are as follows.

This mode is used to check if the sensors in the printer are functioning correctly. In the process of this inspection, the lamps and the switch on the control panel are also checked. On entering this mode, the lamps show the status of the respective sensors as follows.

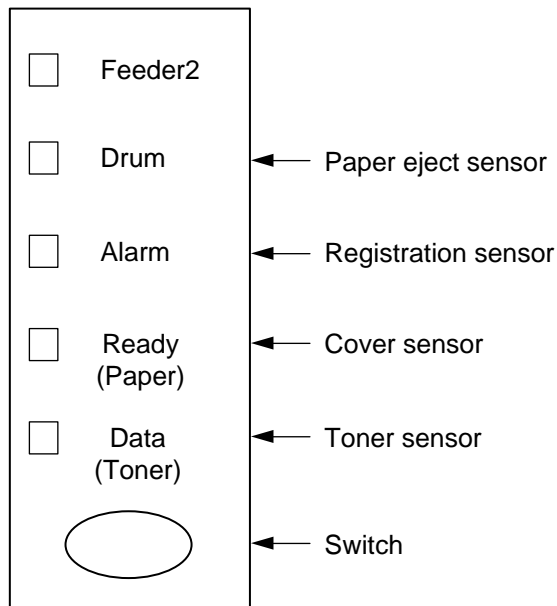

Fig. 4.8

Paper eject sensor	ON (Paper is detected.)	Drum lamp ON
	OFF (No paper is detected.)	Drum lamp OFF
Registration sensor	ON (Paper is detected.)	Alarm lamp ON
	OFF (No paper is detected.)	Alarm lamp OFF
Cover sensor	ON (The top cover is closed.)	Ready lamp OFF
	OFF (The top cover is open.)	Ready lamp ON
Toner sensor	ON (The toner cartridge is installed.)	Data lamp OFF
	OFF (No toner cartridge is installed.)	Data lamp ON

The procedure for the factory inspection mode is as follows.

- (1) Turn the printer power switch OFF, open the top cover, and remove the drum unit.
- (2) Turn the printer power switch ON while holding down the control panel switch. The Drum lamp comes ON.
- (3) Lightly press the panel switch again.
- (4) Check that the Drum(paper eject sensor) and Alarm(registration sensor) lamps go OFF after all the lamps have been ON.
If the paper eject sensor is ON at this point, the Drum lamp stays ON (error).
If the registration sensor is ON at this point, the Alarm lamp stays ON (error).
- (5) Install the drum unit.
Check that the Data lamp goes OFF.
- (6) Lightly touch the registration sensor actuator.
Check that the Alarm lamp comes ON.
- (7) Close the top cover.
Check that the Ready lamp goes OFF.
- (8) Press the control panel switch.
- (9) If all the sensors are correct, the printer goes back to the Ready status. If any error is detected, the corresponding lamp stays ON.

6.2 Error Codes

In the event of a printer failure, error codes will be indicated as shown below. All the lamps and the specific lamps are turned ON alternately. The specific combination of lamps that are ON indicates the type of the error.

Type of error	Data	Ready	Alarm	Drum	Feeder
Fuser Malfunction				○	
Laser BD Malfunction			○		
Scanner Malfunction			○	○	
ROM Error		○			
D-RAM Error		○		○	
Service A *		○	○		
Service B *		○	○	○	
NV-RAM Error	○	○		○	
CPU Runtime Error *	○	○	○	○	
Main Motor Error					○

* Refer to the further description of those errors as follows;

- Service A: Address Error
- Service B: Buse Error
- CPU Runtime Error: The error which CPU other than the above two detects, such as Illegal Instruction or Operation Overflow

HOW THE LED INDICATE AN ERROR

FUSER MALFUNCTION

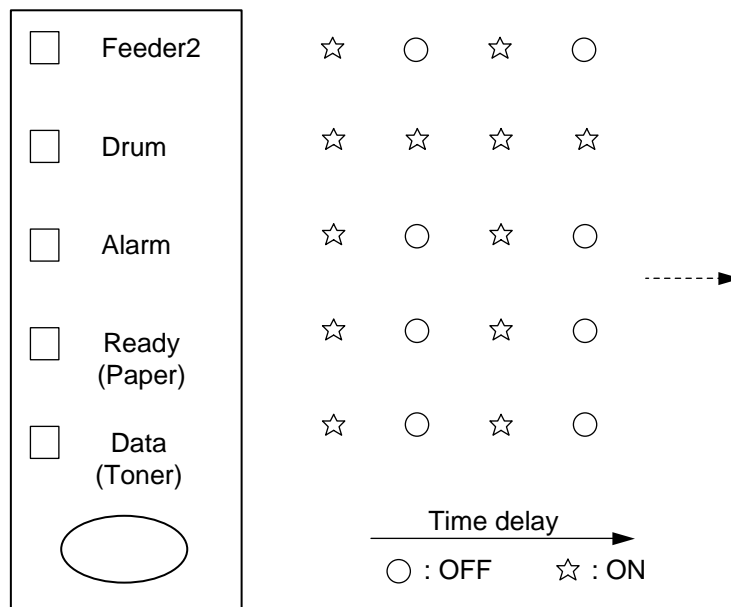

Fig. 4.9

APPENDIX 1. SERIAL NO. DESCRIPTIONS

The descriptions as below shows how to read labels on each place.

< ID for production month >

A: January	E: May	J: September
B: February	F: June	K: October
C: March	G: July	L: November
D: April	H: August	M: December

(1) Printeron the main body

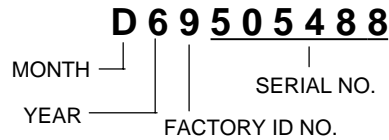

(2) Process uniton the package of the process unit
(Drum unit with toner cartridge)

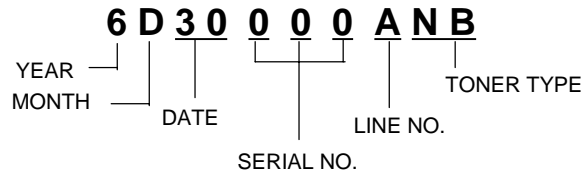

(3) Drum uniton the drum unit

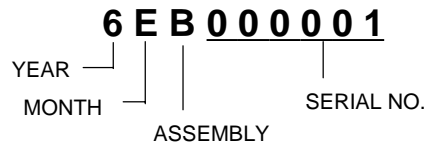

(4) Toner cartridgeon the toner cartridge

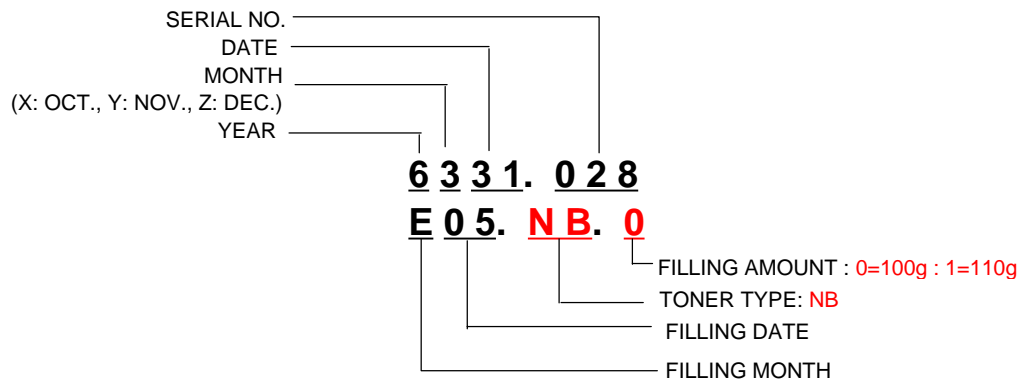

(5) Scanner uniton the scanner unit

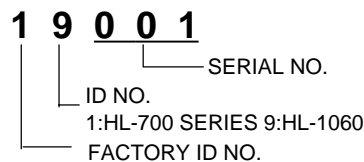

Appendix 4. Main PCB Circuit Diagram, (2/4)

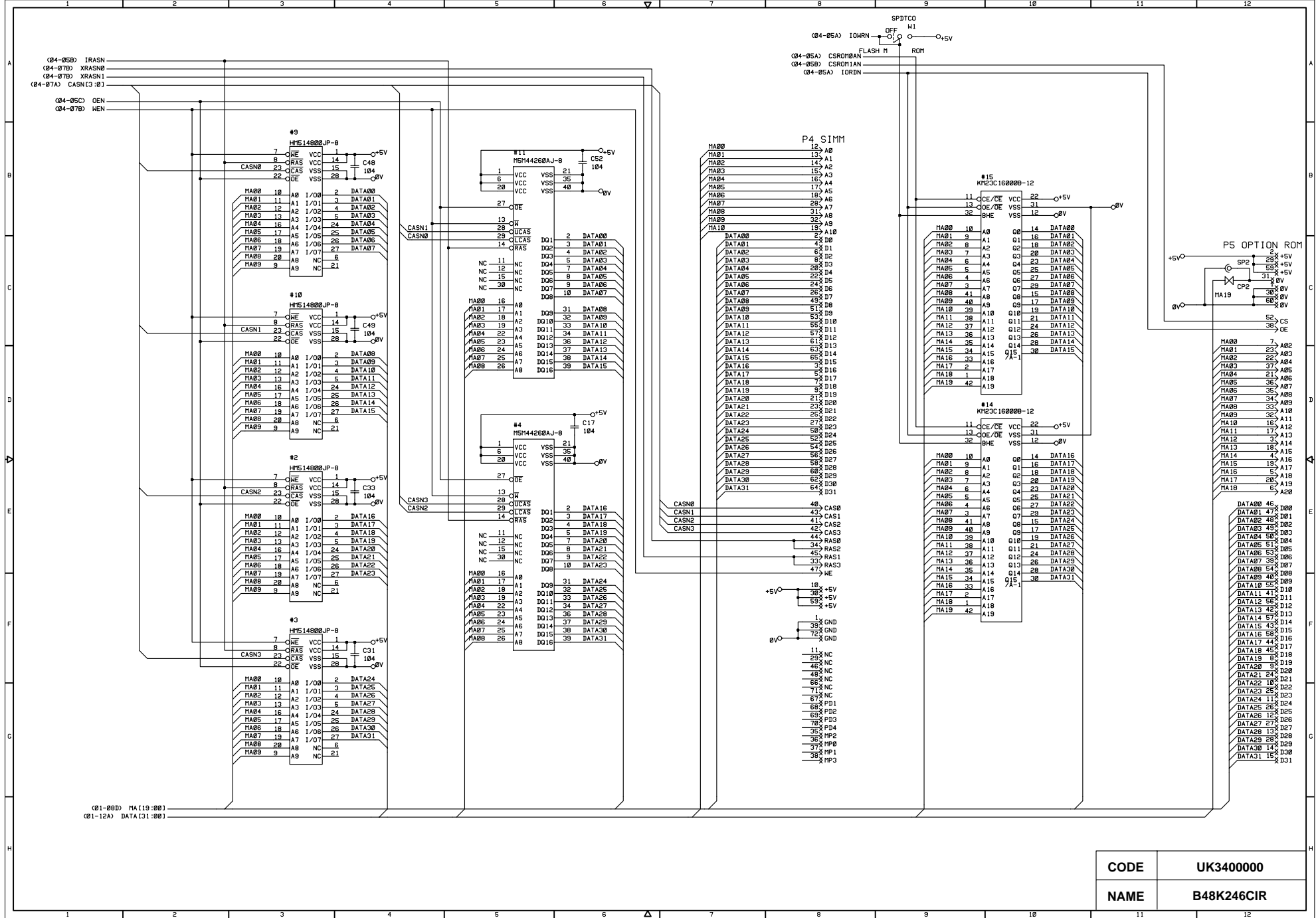

CODE	UK340000
NAME	B48K246CIR

Appendix 5. Main PCB Circuit Diagram, (3/4)

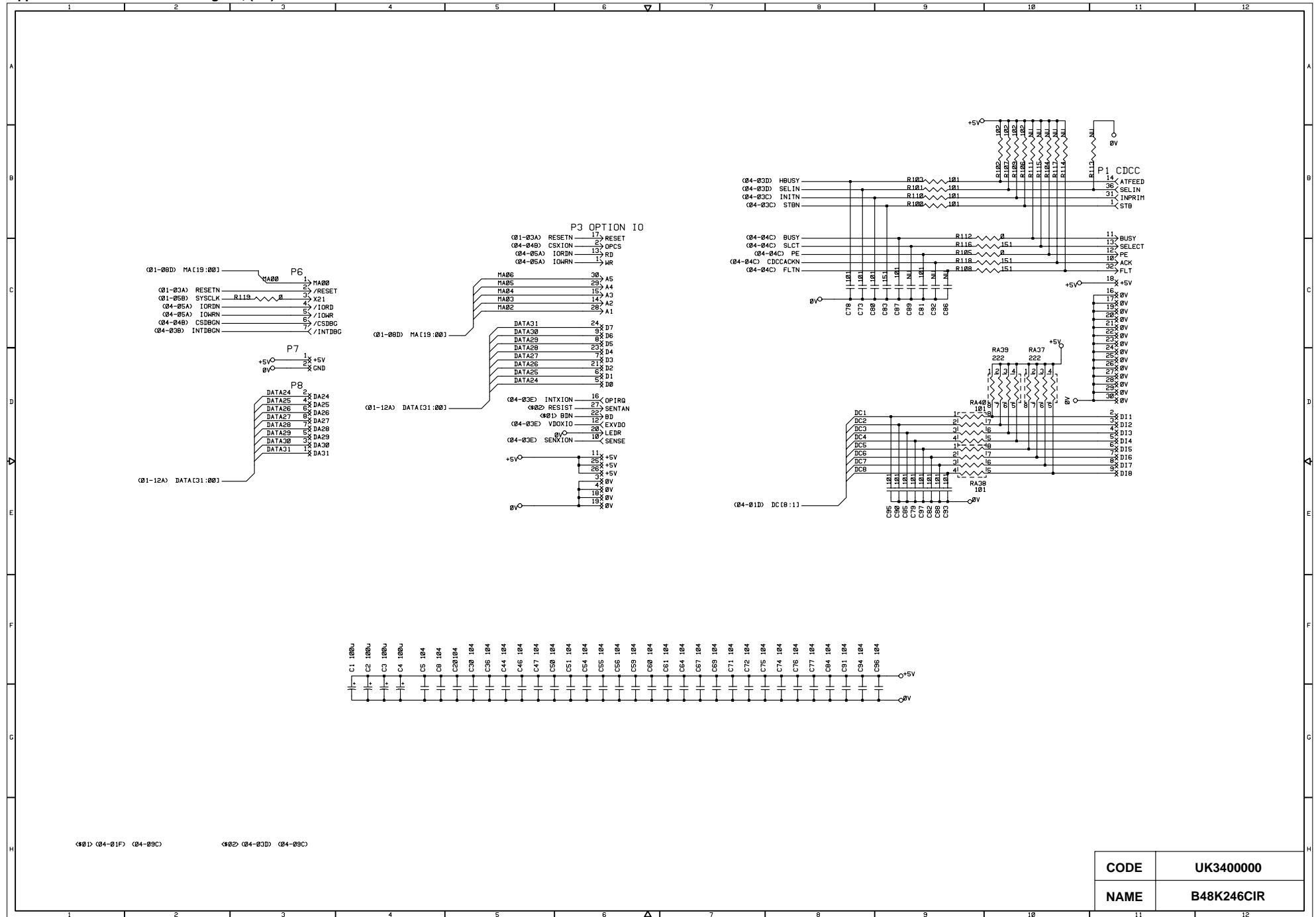

CODE	UK340000
NAME	B48K246CIR

Appendix 6. Main PCB Circuit Diagram, (4/4)

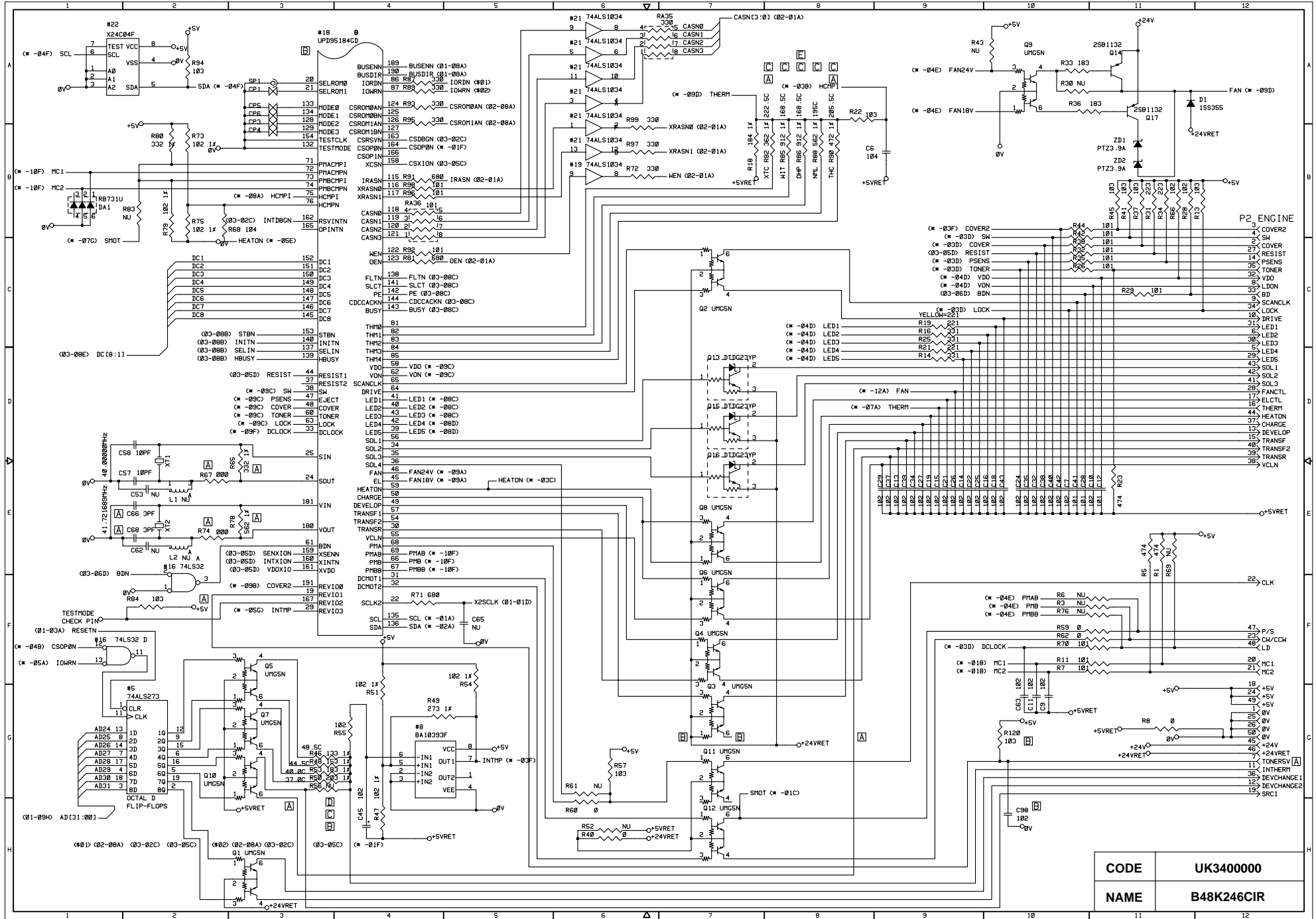

CODE	UK340000
NAME	B48K246CIR

Appendix 7. Driver PCB Circuit Diagram

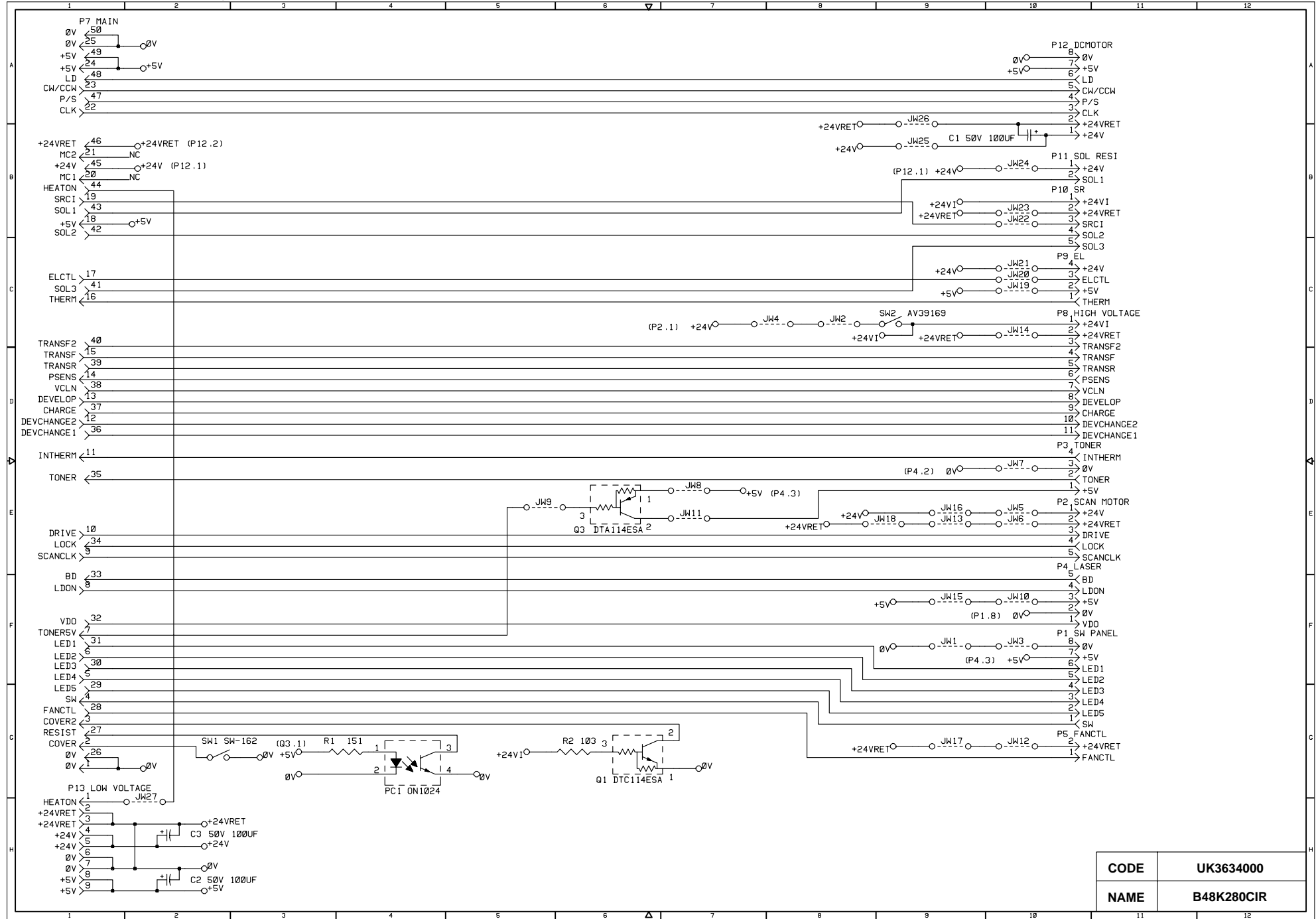

Appendix 8. Switch Panel / Solenoid, Bin / Relay PCB Circuit Diagram

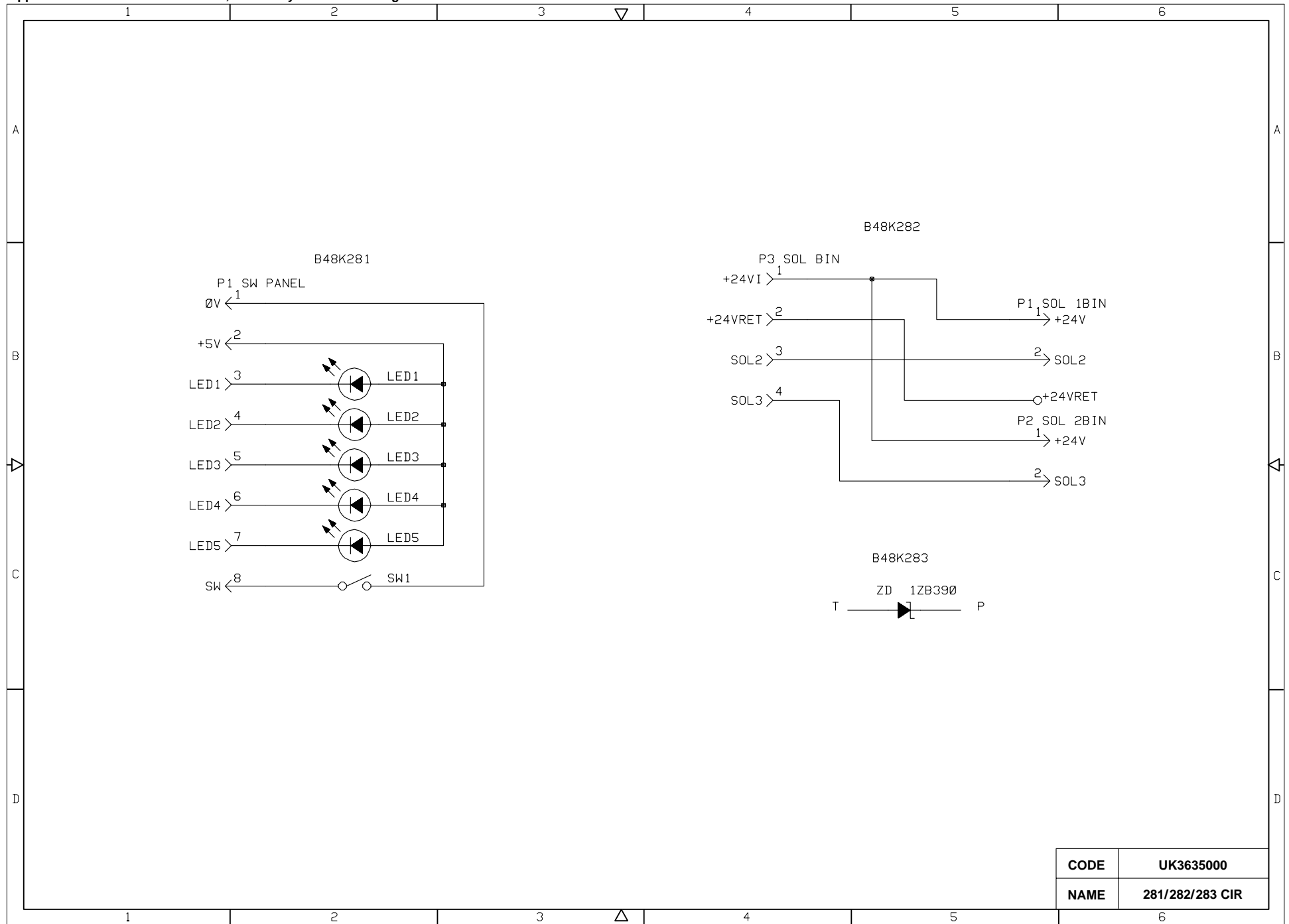

CODE	UK3635000
NAME	281/282/283 CIR

Appendix 9. Low-voltage Power Supply PCB Circuit Diagram (110 - 120V)

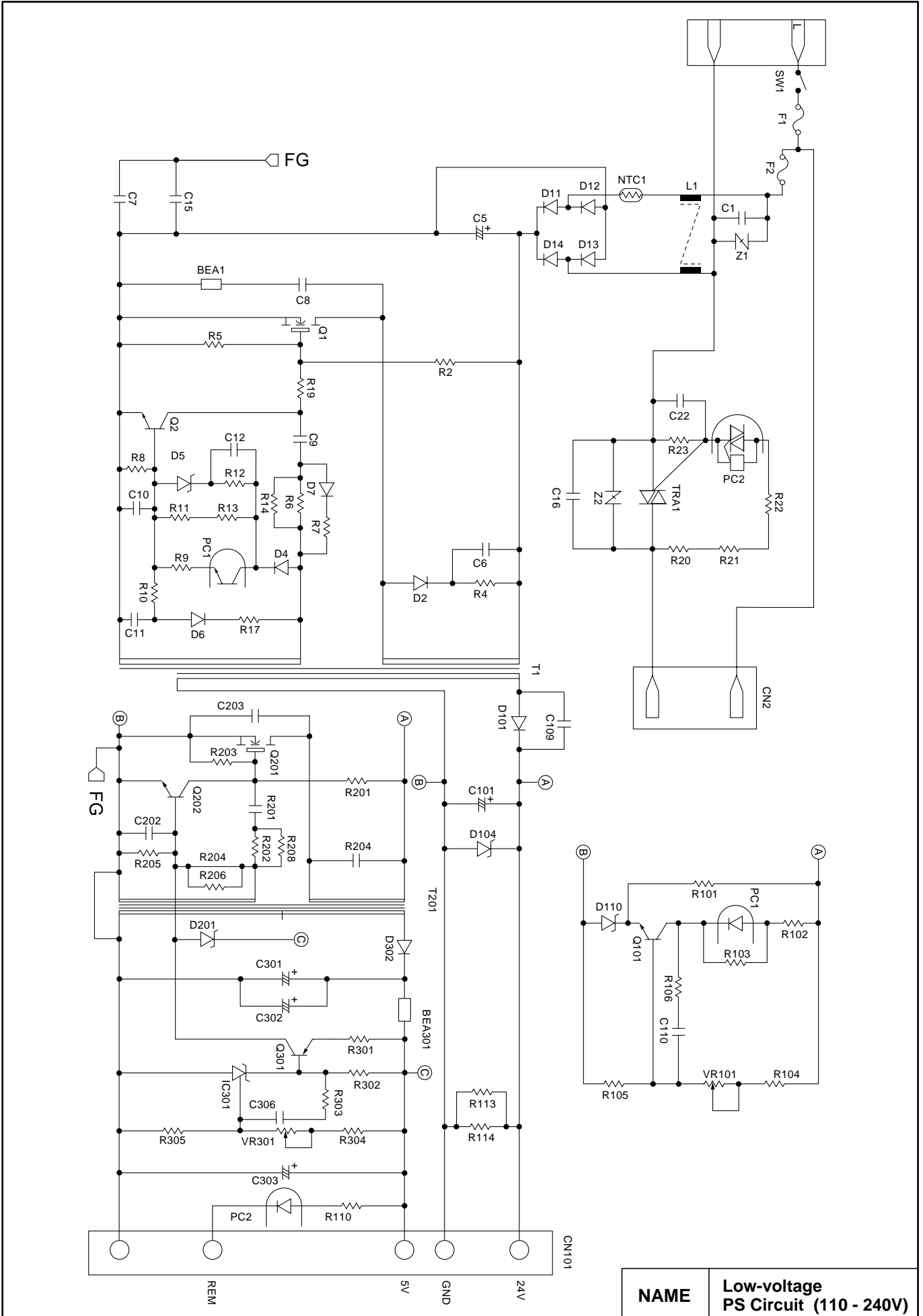

NAME	Low-voltage PS Circuit (110 - 240V)
------	-------------------------------------

Appendix 10. Low-voltage Power Supply PCB Circuit Diagram (220 - 240V)

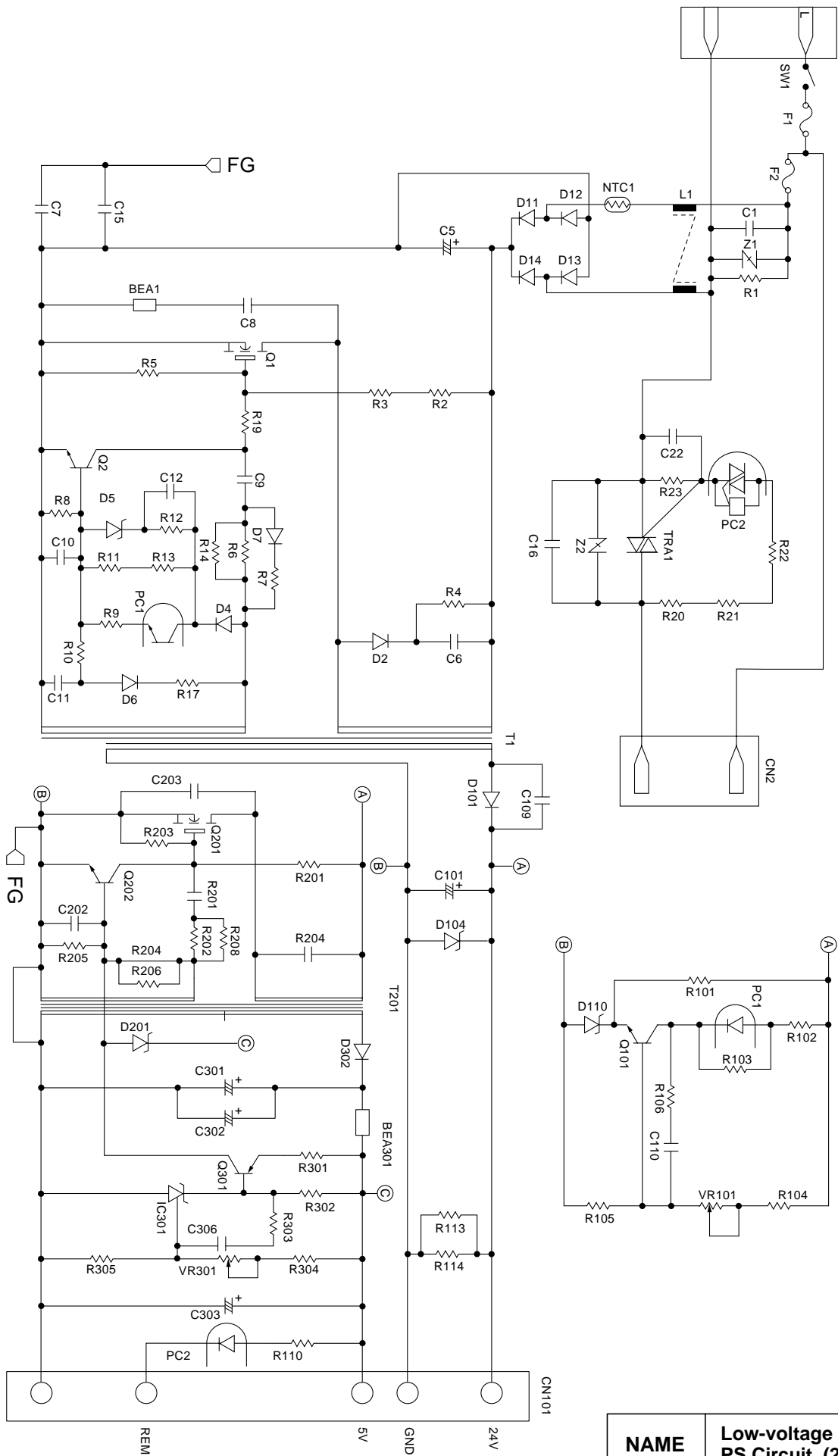

NAME	Low-voltage PS Circuit (220 - 240V)
-------------	--

Appendix 11. High-voltage Power Supply PCB Circuit Diagram

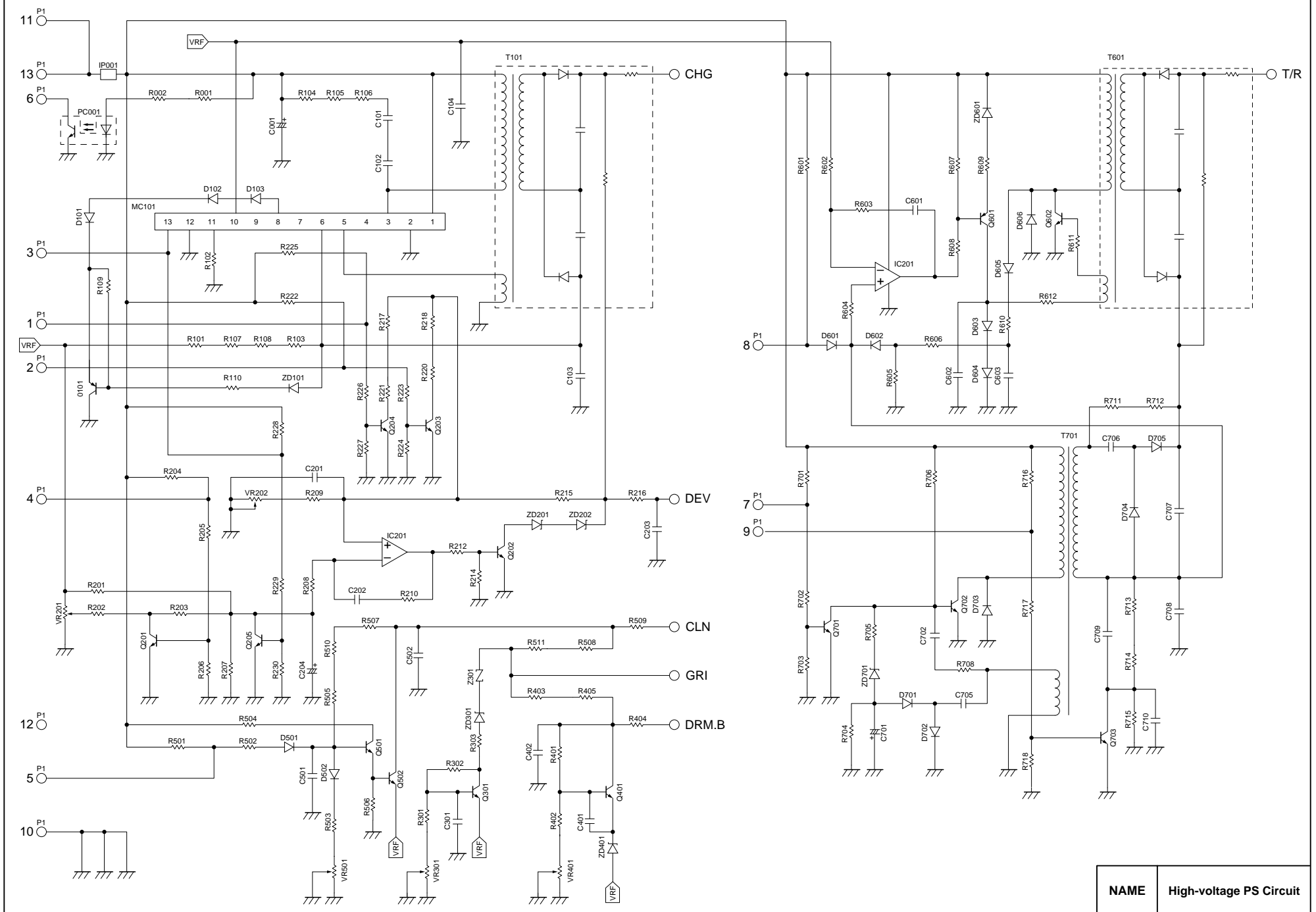

NAME	High-voltage PS Circuit
------	-------------------------

Appendix 12. SR PCB Circuit Diagram

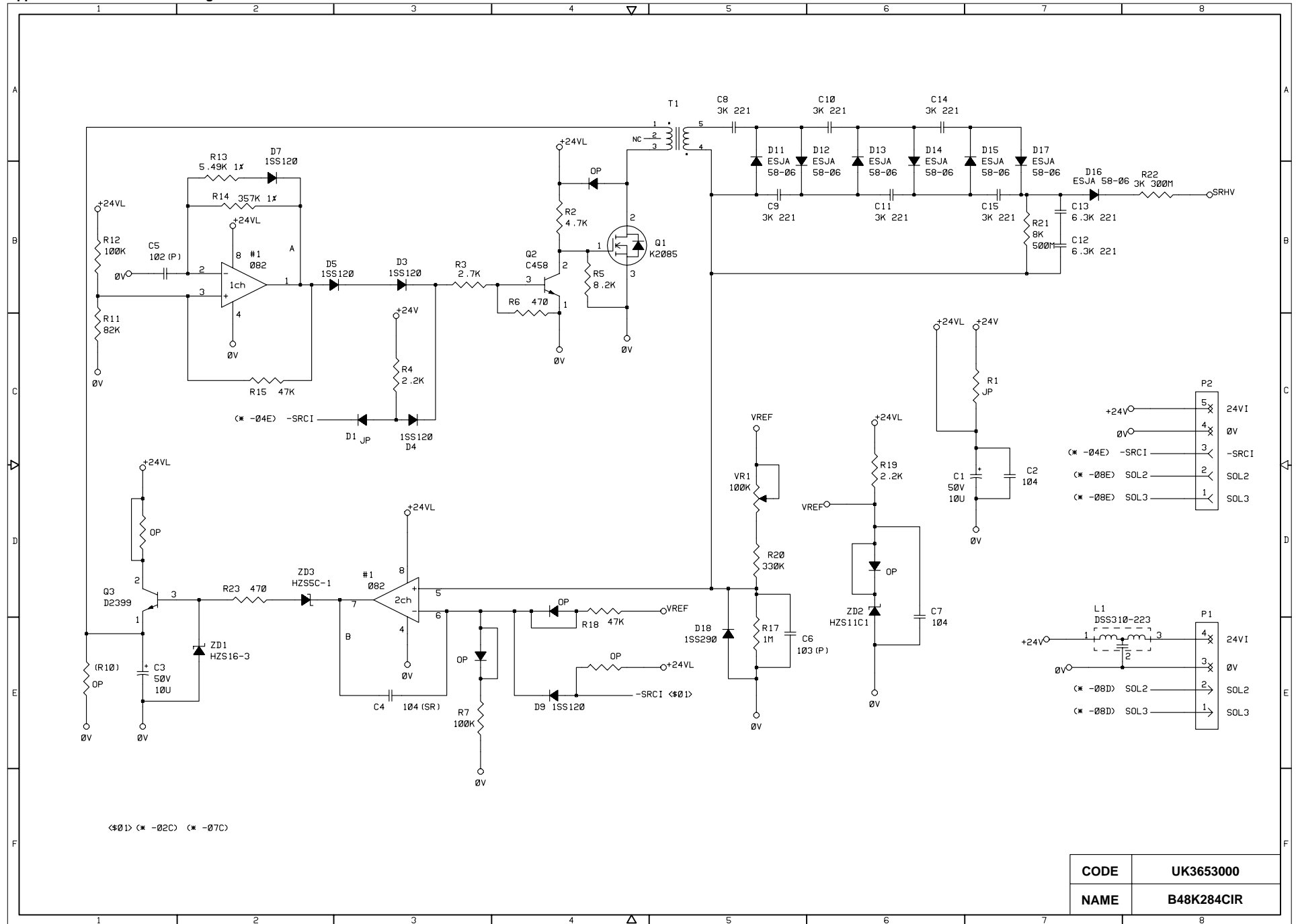

CODE	UK3653000
NAME	B48K284CIR